

Owner's Manual & Installation Guide



for the **Santa Fe** (8780)
VENT FREE HEATER



READ THIS OWNER'S MANUAL

Operate and maintain this gas heater according to this instruction manual.
Read This Manual In Its Entirety.

WARNING: If the information in these instructions is not followed exactly, a fire or explosion may result causing property damage, personal injury or loss of life.

Do not store or use gasoline or other flammable vapors and liquids in the vicinity of this or any other appliance.

WHAT TO DO IF YOU SMELL GAS:

- Do not try to light any appliance.
- Do not touch electrical switches; do not use the phone in your building.
- Immediately call your gas supplier from a neighbors phone. Follow your gas suppliers instructions.
- If you cannot reach your gas supplier, call the fire department.

A qualified installer, service agency or gas supplier must perform installation and service. In the Commonwealth of Massachusetts, all installation of gas lines and gas fitting shall only be done by a licensed gas fitter or licensed plumber.



We recommend that our products be installed and serviced by professionals who are certified in the U.S. by NFI (National Fireplace Institute).

www.nficertified.org



Model # 8780
6400-40438 11-4-04

317 Stafford Avenue,
Morrisville, Vermont 05661
E-Mail: inquiry@hearthstonestoves.com.

INFORMATION SHEET

Record, on this page, all relevant information concerning the purchase, installation, and maintenance of your SANTA FE Gas-Fired Vent Free Heater. This information will facilitate servicing, purchase of replacement parts, and warranty claims (if necessary). Keep your original receipt in a safe place as proof of purchase.

Serial Number: _____

Fuel type (check one) _____ Natural Gas _____ Liquid Propane

Sold by: _____

Phone: _____ Date of Purchase: _____

Installed by: _____

Phone: _____ Date of Installation: _____

Gas Supplier: _____

Phone: _____

Read this Owner's Manual before installing or operating the SANTA FE heater. Retain this manual for future reference.

SERVICE RECORD

Date	Who Performed Work	Work Performed	Notes

WELCOME

Congratulations on your purchase of a Santa Fe Gas-Fired Vent Free heater. The Santa Fe, by HearthStone Cast Iron Stoves, incorporates the latest in vent free gas technology, which will provide you with clean, efficient heat for years to come. The combination of natural stones with cast iron give the Santa Fe a pleasing look, which can be maintained with minimum care. The Santa Fe will provide you with years of practical and convenient service. However, as with any gas appliance, the unit must be properly and safely installed and maintained by qualified service personnel to ensure safe and trouble-free operation.

READ THIS OWNER’S MANUAL

Operate and maintain this gas heater according to the instructions in this manual. Read this manual in its entirety. This manual has two sections, the first section is for the *OPERATOR*, and the second section is for the *QUALIFIED SERVICE PERSONNEL* only.

HEATER MUST BE INSTALLED AND MAINTAINED BY QUALIFIED SERVICE PERSONNEL

Verify the gas connections with requirements of local, regional or national installation codes. Qualified service personnel must inspect the gas heater before use and at least once annually.

FIRE HAZARD

Do not store or use gasoline or other flammable vapors or liquids in the vicinity of this appliance. The Santa Fe should be located out of traffic and away from furniture, draperies, clothing, and flammable material.

Table of Contents

WELCOME 2

OWNER’S INFORMATION..... 3

 LIGHTING INSTRUCTIONS..... 4

 DAILY OPERATIONS 4

INSTALLER’S INFORMATION..... 4

 UNPACKING AND INSPECTION..... 5

 CERAMIC FIBER LOG SAFETY INFORMATION 5

 STOVE DIMENSIONS & CLEARANCES TO COMBUSTIBLES 6

 FRESH AIR REQUIREMENTS..... 7

 GAS CONNECTIONS 10

 LOG PLACEMENT..... 10

 LIGHTING THE UNIT FOR THE FIRST TIME 12

 INITIAL ADJUSTMENTS 12

ROUTINE MAINTENANCE AND CARE..... 13

PARTS LISTS..... 15

MANUFACTURED BY:
 HearthStone *Quality Home Heating Products ,Inc.*
 317 Stafford Avenue
 Morrisville, Vermont 05661 USA

	NG	LP
Input rating(Btu/hr) 0-2000ft	36,000	39,000
Minimum input rating(Btu/hr)	24,000	31,000
Orifice size DMS 0-2000ft	31	49
Man. pressure- HI setting (in.w.c.)	3.5	10.0
Man. pressure- LO setting (in.w.c.)	1.6	6.4
Minimum inlet pressure (in.w.c.)	5.0	11.0

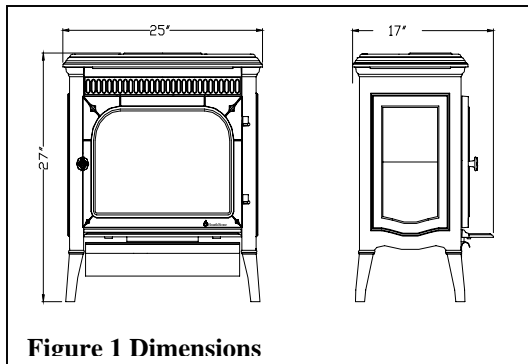

Figure 1 Dimensions

SERVICE CAUTION

Any shield, door, or other component removed for servicing must be replaced prior to operating. Any components of the stove removed for servicing must be replaced prior to operating. If you believe your Santa Fe is not performing properly, immediately discontinue operation until the unit has been inspected and approved by qualified service personnel. Prior to servicing the unit, turn the valve control knob clockwise to “OFF”. The unit should be cool prior to servicing and cleaning. **Any safety screen, guard, or component removed during servicing should be replaced prior to operation.** Do not use any components on the stove other than those approved by HearthStone Quality Home Heating Products, Inc., otherwise all warranties are void. **Do not substitute components.**

HOT SURFACES

Certain exposed surfaces of the Santa Fe will reach high temperatures during normal operation. Clearances to combustibles must be maintained, as specified in the “Clearances To Combustibles” section of this manual. **Due to high temperatures the appliance should be located out of traffic and away from furniture, draperies, clothing and flammable materials. Children and adults should be alerted to the hazards of high surface temperatures and should stay away to avoid burns to skin or clothing ignition. Young children should be carefully supervised when in the same room as the appliance. Clothing or other flammable material should not be placed on or near the appliance.** Clean the area around, under, and behind the unit on a regular basis to prevent the accumulation of dust and lint.

OWNER’S INFORMATION

The installation must conform with local codes or, in the absence of local codes, the current National Fuel Gas Code, ANSI Z223.1 (NFPA 54) or **Do not use this appliance if any part has been under water. Immediately call a qualified service technician to inspect the heater and to replace any part of the control system and gas control which has been under water.**

WARNING

Do not use this room heater if any part has been under water. Immediately call a qualified service technician to inspect the room heater and to replace any part of the control system and any gas control, which has been under water.

WARNING

Installation and repair should be done by a qualified service technician. The appliance should be inspected before use and at least annually by a qualified service technician. More frequent cleaning may be required due to excessive lint from carpeting, bedding material, etc. It is imperative that control compartments, burners, and circulating air passages of the appliance are kept clean and free of obstructions.

LIGHTING INSTRUCTIONS

1. Set the on/off/T-stat switch or thermostat to the off position.
2. Push in and turn gas control knob clockwise to “OFF”. *(If not previously lit, the knob should be in this position.)*
3. Wait (5) five minutes to clear out any gas. If you then smell gas, STOP! *Smell all around the appliance area for gas. Be sure to smell next to the floor because some gases are heavier than air and will settle on the floor. If you smell gas, immediately follow the What To Do If You Smell Gas! warning on the cover of this Manual.* If you do not smell gas, go to the next step.
4. Turn gas control knob counterclockwise to “PILOT”.
5. Push in control knob all the way and hold in. Immediately light the pilot with the gas lighter (push in and “click” the red piezoelectric spark ignitor button several times until lit). Continue to hold the control knob in for about 20 seconds after the pilot is lit. Release the knob and it will pop back out. Pilot should remain lit. If the pilot goes out, repeat the operation.
 - * If knob does not pop out when released, stop and immediately call a qualified service technician or gas supplier.
 - * If the pilot will not stay lit after several tries, turn the gas control knob “OFF” and call a qualified service technician or gas supplier.
6. Turn gas control knob counterclockwise to “ON”.
7. Select “ON” or “T-STAT” position on the on/off/t-stat switch.
8. Shut the gas control valve access door.
9. Plug in the fan accessory, if so equipped.
10. Set thermostat to “ON” and set the desired temperature setting.

Normally, if the “T-STAT” position was selected, the main burner is cycled on and off by the Thermostat or the “on”, “off” switch located on the bottom of the Thermostat body.

TO TURN OFF GAS TO APPLIANCE

1. Turn the gas control knob clockwise to “OFF” position. *If shutting the unit off for the non-heating season, this will improve the overall efficiency of the unit as the heat from the pilot is wasted in the summer. When putting the unit back into service follow the lighting instructions described on this page.*

VARIABLE OUTPUT CONTROL

The gas control valve is equipped with a variable output control. This control varies the rate of heat produced by the unit by varying the gas pressure to the main burner tube.

DAILY OPERATIONS

The homeowner easily operates the Santa Fe gas-fired heater. The unit comes standard with a thermostat, while a remote or wall switch may be purchased from your Retailer. Once the thermostat is installed and adjusted, the desired room temperature will be maintained. By adjusting the variable output control located on the gas control valve, the rate of heat output can be varied to meet the heating requirements of the season. Choosing a low flame setting will result in longer burn cycles at a reduced output, while choosing a high flame setting will result in a shorter, hotter burn cycle. Through trial and error, the homeowner can select the optimum flame size for their setting and application.

INSTALLER’S INFORMATION

SPECIFICATIONS:

LISTED: DIRECT VENT GAS HEATER

Model: Santa Fe VF

Testing Agency: Intertek Testing Services
NA Inc. (ITS)

Tested to: ANSI Z21.11.2b-2002•

Codes

Adhere to all **local codes** or, in their absence, the latest edition of THE NATIONAL FUEL GAS

CODE ANSI Z223.1 (NFPA 54), which can be obtained from:

**AMERICAN NATIONAL STANDARDS
INSTITUTE, INC.**

1430 BROADWAY
NEW YORK, NY 10018

OR

**NATIONAL FIRE PROTECTION
ASSOCIATION, INC.**

BATTERY MARCH PARK
QUINCY, MA 02269

A manufactured home (mobile) OEM installation must conform with the Manufactured Home Construction and Safety Standard, Title 24 CFR, Part 3280 (U.S.) or Standard for Manufactured Home Installation, ANSI/NCBCS A225.1 or Standard for Gas Equipped Recreational Vehicles and mobile Housing,

UNPACKING AND INSPECTION

Unpack and Inspect for Damage

The Santa Fe is packaged by the manufacturer to withstand shipment without damage. However, damage can occur during transit so take care to inspect for damage when unpacking and installing the unit. If any damage or missing parts are detected, immediately contact your dealer. Do not install or put into service a damaged or incomplete heater.

The unit should appear to be square and level. The sheet metal parts should be smooth and free of bends or dents. The enameled cast iron should be free of chips or cracks. If visible or concealed damage is found, contact your dealer.

To open the firebox: remove the front door screw with supplied Allen wrench, and swing the door open. Remove the lag bolts, which fasten the unit to the pallet. Take care not to chip the enameled legs. Lift the stove off the pallet and set it into place.

CERAMIC FIBER LOG SAFETY INFORMATION

The decorative ceramic fiber logs supplied with the Santa Fe are located in the firebox. Always use great care when handling the decorative

ceramic logs, as they are fragile and subject to damage and breakage. If the decorative ceramic logs and ember screen supplied with the Santa Fe are damaged they must be replaced. Replacement parts must be supplied by the manufacturer. Do not replace ceramic logs or the ember screen with any materials not approved by HearthStone Quality Home Heating Products Inc.

Packing List

1-Santa Fe Gas-fired Heater containing:
4-Decorative Ceramic Fiber Logs
1-Ember Screen
1-Charcoal Embers
1-Owner's Manual and Warranty

1-Accessory box containing:
1- 1/8" Allen key for front door
1-Ash Lip
1-Top Grille
1-Thermostat with Thermostat Wire
2-Extension control Knobs

ITEMS REQUIRED FOR INSTALLATION

- * External regulator (for propane/L.P.G. only)
- * Piping which complies with local codes
- * Pipe sealant approved for use with propane (L.P.G.) (resistant to sulfur compounds)
- * Manual shutoff valve
- * Sediment trap
- * Tee joint
- * Pipe wrench
- * Phillips head screwdriver
- * Other parts as required by local code
- * Safety Glasses
- * Gloves

STOVE DIMENSIONS & CLEARANCES TO COMBUSTIBLES

Always maintain clearances around the air openings around the stove. This allows for adequate ventilation

HEARTH REQUIREMENT

The Santa Fe may be placed on a non-combustible surface or wood floor. For placement of the Santa Fe on carpeting, vinyl tile or other combustible materials, the appliance shall be installed on a metal or wood panel extending the full width and depth of the appliance. Installations must meet local codes.

Conditionally approved for purchased mobile home installation. This appliance may be installed in an aftermarket permanently located, manufactured (mobile) home, except where prohibited by local codes.

This appliance is only for use with the type of gas indicated on the rating plate. This appliance is not convertible for use with other gases.

- A = 2"
- B = 4"
- C = 2"

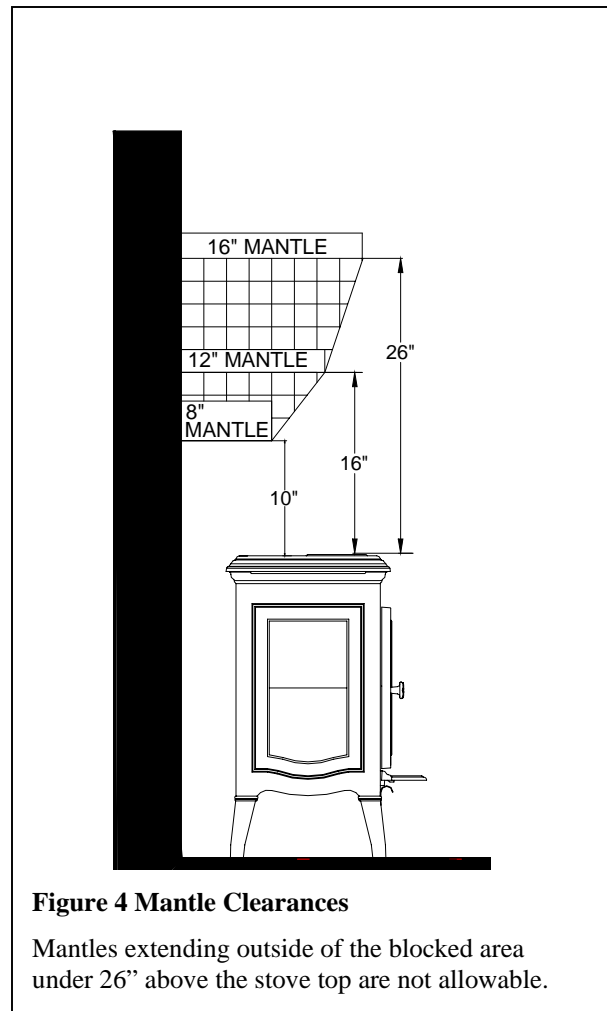
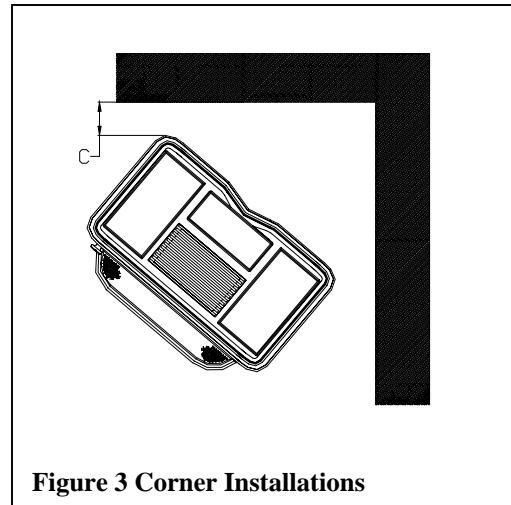
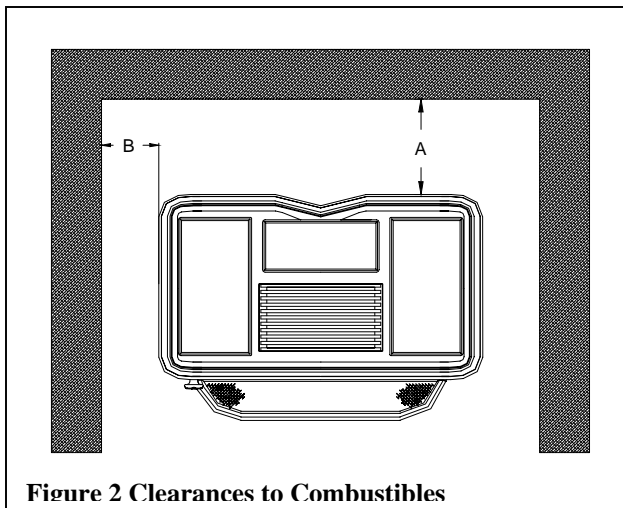

FRESH AIR REQUIREMENTS

Your Santa Fe stove requires an adequate supply of fresh air to function properly and safely. The fresh air supply must be met within the space in which the heater is to be installed. To ensure an adequate supply of fresh air is available for proper and safe operation of your Santa Fe stove, the following information must be considered when installing the appliance in a mobile home, modular home, or an on-site house, Refer to Figure 5.

The space in which the heater should be installed will fall into one of the following categories:

1. Unusually tight construction
2. Unconfined space
3. Confined space

WARNING: If the area in which the heater may be operated is smaller than that defined as an unconfined space, provide adequate combustion and ventilation air by one of the methods described in the National Fuel Gas Code ANSI Z223.1, Latest Edition, Section 5.3.

Determining Space Classification

Unusually tight construction

This is construction where:

- a. Walls and ceilings exposed to the outside atmosphere have a continuous water vapor retarder with a rating of one perm (6×10^{-11} kg per pa-sec-m²) or less with openings gasketed or sealed, and
- b. Weatherstripping has been added on openable windows and doors, and
- c. Caulking or sealants are applied to areas such as joints around window and door frames, between sole plates and floors, between wall ceiling joints, between wall panels, at penetrations for plumbing, electrical, and gas lines, and at other openings.

If the space in which the heater will be installed falls into this category, supplemental fresh air must be provided, as outlined in the Meeting Fresh Air Requirements section of this manual.

Unconfined space

If the space in which the heater is to be installed meets the following criteria, it is considered to be an unconfined space.

The room in which the heater is to be installed has an air volume of at least 50 cubic feet (cubic feet = length x width x height of the space) for each 1000 BTU/hr (4.8 m³ / K. W.) input rating for all appliances in the space. This includes adjoining rooms only if there are doorless passageways between them, or there are vents between the rooms. If the space in which the unit is being installed is an unconfined space, additional fresh air is not needed.

Confined space

If the space in which the heater is to be installed meets the following criteria, it is considered a confined space. The room in which the heater is to be installed has an air volume of less than 50 cubic feet for each 1000 BTU/hr (4.8 m³ / K. W.) input rating for all appliances in the space. This includes adjoining rooms only if there are doorless passageways between them, or there are vents between the rooms.(See Figure 5).

If the space in which the heater is to be installed is a confined space, additional fresh air must be provided. This can be done by one of the ways outlined in the Meeting Fresh Air Requirements section of this manual.

Example (refer to Figure 5)

I. Determine the volume of the space where the unit will be installed. Volume = length x width x height. Also included in the volume of the space is the volume of any adjoining rooms, only if there are doorless passage ways between them, or if there are vents between the rooms.

II. Multiply the volume by 1000 BTU/hr, then divide that number by 50 cubic feet, to obtain the total maximum BTU/hr rating which the room can support.

III. Add the BTU/hr ratings of all fuel burning appliances installed within the same space. The BTU rating for this unit is 3900 BTU/hr. (Do not

include any direct vent appliances, as these types of appliances use outside air for combustion and venting).

IV. Compare the maximum BTU/hr rating that the room can support (from II.) with the maximum BTU/hr rating of the combined appliances (from III.). If the number from III. is

smaller than the number calculated in II., the space should be considered an unconfined space. If the number from III. is larger than II., the space should be considered a confined space, and additional fresh air must be provided. This can be done by one of several ways.

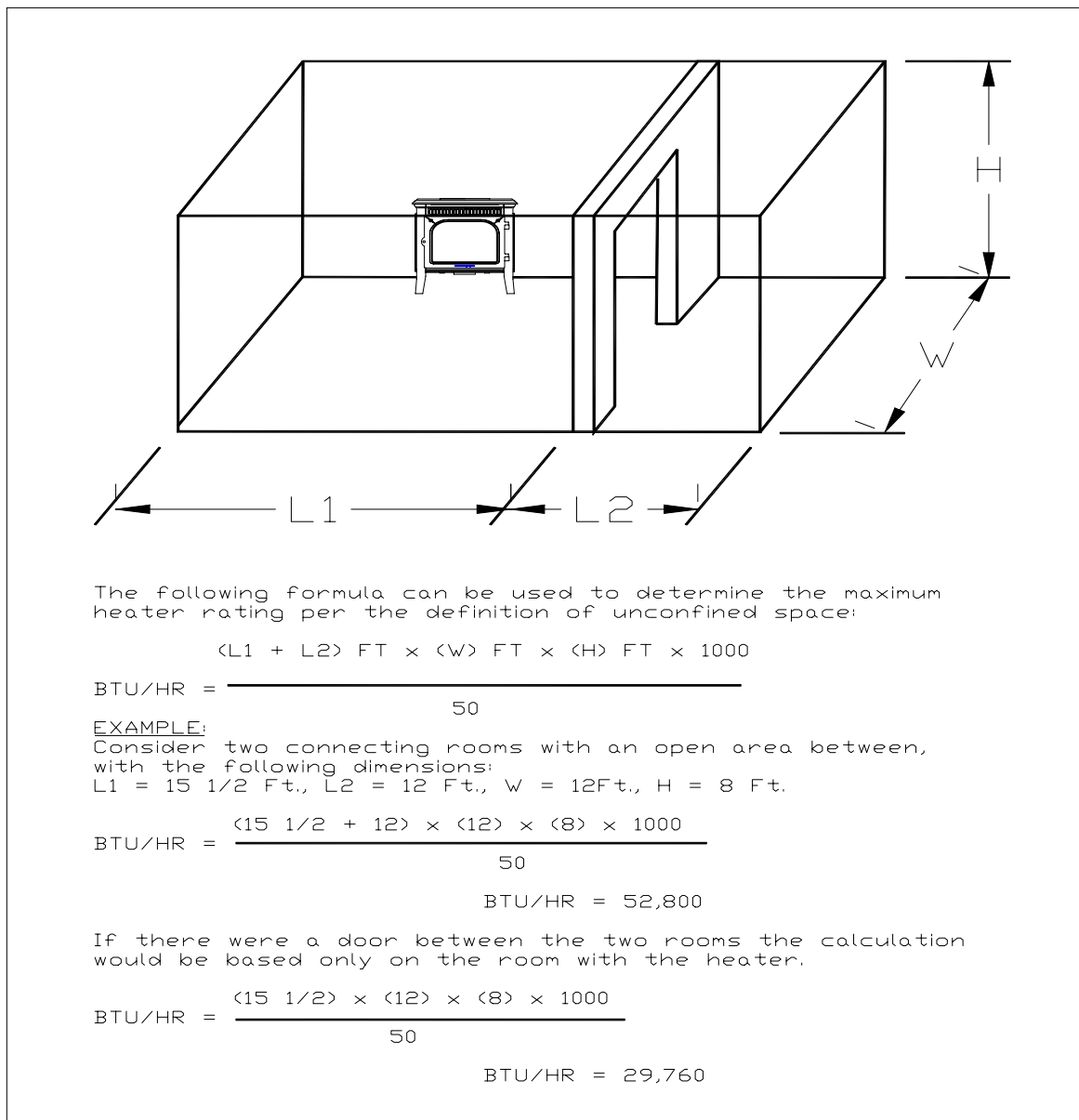

Figure 3 Confined Spaces

Meeting Fresh Air Requirements

1. *Air from inside the building.* The confined space shall be provided with two permanent openings communicating directly with an additional room(s), of sufficient volume, so that the combined volume of all spaces meets the criteria for an unconfined space. The total input of all gas utilization equipment installed in the combined space shall be considered in making this determination. Each opening shall have a minimum free area of 1 square inch per 1,000 BTU/hr (22 cm² / kW) of the total input rating of all gas utilization equipment in the confined space, but not less than 100 square inches (645 cm²). One opening shall commence within 12 inches (30 cm) of the top, and one opening shall commence within 12 inches (30 cm) of the bottom, of the enclosure. The minimum dimension of air openings shall not be less than 9 square inches (8 cm) (see Figure A).

2. *All air from outdoors.* The confined space needs to have two permanent openings, one commencing within 12 inches (30 cm) of the top, and one commencing within 12 inches (30 cm) of the bottom, of the enclosure. The openings shall communicate freely with the outdoors, either directly, by ducts, or by spaces (crawl or attic). The minimum dimension of air openings shall be not less than 9 square inches (8 cm). See Figures B thru D.

A. Where directly communicating with the outdoors, each opening shall have a minimum free area of 1 square inch per 4,000 BTU/hr (5.5 cm² / kW) of total input rating of all equipment in the enclosure. See Figure B.

B. Where communicating with the outdoors through vertical ducts, each opening shall have a minimum free area of 1 square inch per 4,000 BTU/hr (5.5 cm² / kW) of total input rating of all equipment in the enclosure (See Figure C).

C. Where communicating with the outdoors through horizontal ducts, each opening shall

have a minimum free area of 1 square inch per 2,000 BTU/hr (11 cm² / kW) of total input rating of all equipment in the enclosure (See Figure D).

D. Where ducts are used, they shall be of the same cross-sectional area as the free area of the openings to which they connect.

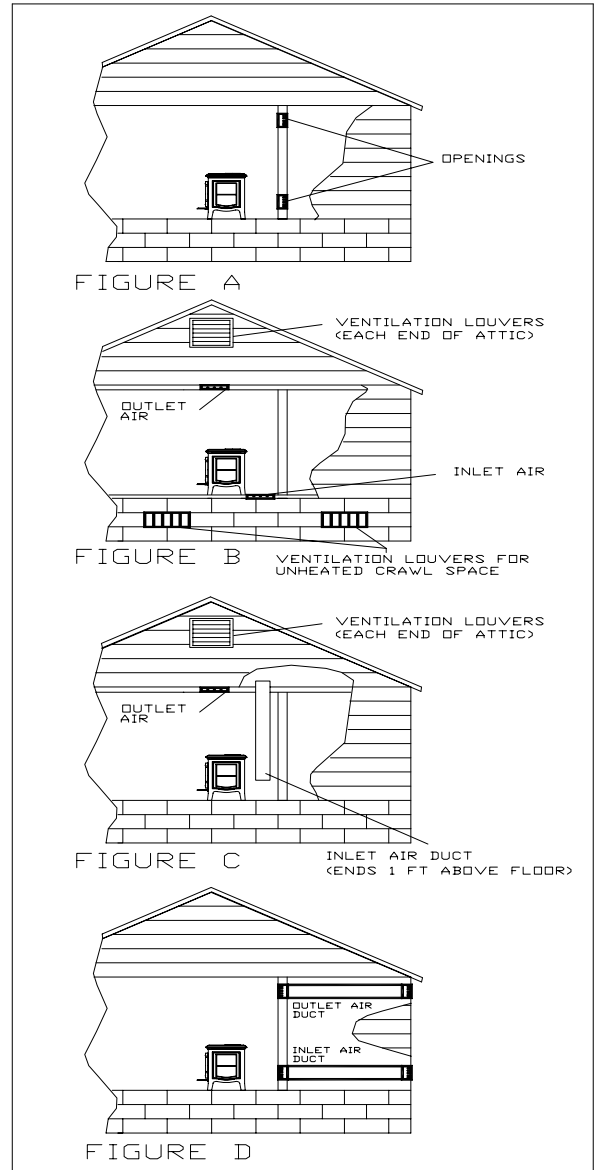

GAS CONNECTIONS

The gas supply line connection is made to the Santa Fe's gas control valve under the unit on the left side using a 3/8" NPT fitting. It should be sized to provide a sufficient gas supply to meet the maximum demand of the unit without undue loss of pressure.

Once connected to the gas supply the gas inlet pressure and manifold gas pressure must be tested. The supply line must include a manual shut-off valve and union so that the unit can be disconnected for servicing. The gas control valve has built in pressure taps for test gauge connections (#'s 6 & 7 in Figure 6). The supply line pressure must be tested to ensure it meets the minimum pressure for the type of fuel in use (NG or LP).

appliance must be isolated from the gas supply piping system by closing its individual manual shutoff valve during any pressure testing of the gas supply piping system at test pressures equal to or less than 1/2 psig.

Pressure Measurements: To measure the pressure of gas directly upstream of the supply connection, connect a manometer to the gas inlet tap(6) and manifold pressure tap (7) in Figure 6

WARNING

Do not use substitute materials. Use only parts that have been supplied through HearthStone, or a HearthStone dealer.

VALVE DESCRIPTION

- | | | |
|--|------------------------------|-----------------------------------|
| ① Gas cock knob | ⑥ Inlet pressure test point | ⑪ Flange securing screw holes |
| ② Manual HI-LO adjustment or pressure regulator adjustment | ⑦ Outlet pressure test point | ⑫ Additional valve mounting hole |
| ③ Pilot adjustment | ⑧ Main operator | ⑬ Alternative TC connection point |
| ④ Thermocouple connection | ⑨ Pilot outlet | ⑭ Thermoelectric unit |
| ⑤ Mounting for piezo & bracket | ⑩ Main gas outlet | |

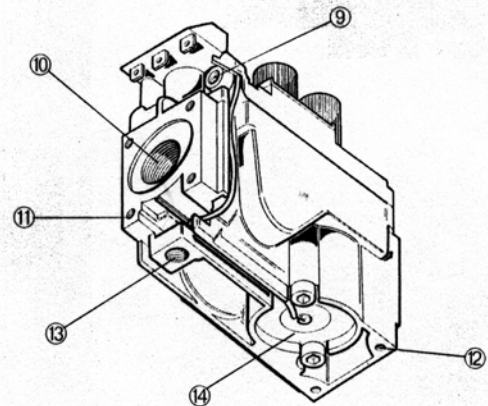
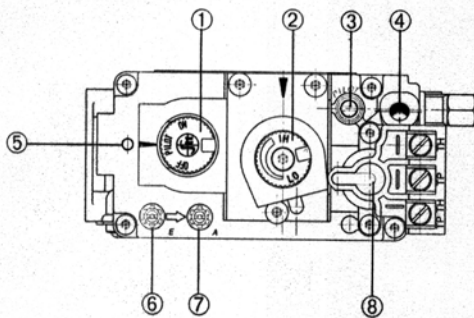

Figure 4 Gas Control

GAS PRESSURE ADJUSTMENT

A qualified technician must connect the heater to the gas supply and leak test the unit before it is approved for use. Consult all local codes. The appliance and its appliance main gas valve must be disconnected from the gas supply piping system during any pressure testing of that system at test pressures in excess of 1/2 psig. The

LOG PLACEMENT

Only the decorative ceramic fiber log set supplied with the unit should be placed in the firebox. Do not place any other ceramic logs, wood logs, or other materials in the firebox. If the log set is damaged or broken contact your dealer for replacement. The decorative ceramic fiber log set will last a long time, however, they will break if subjected to rough or improper

handling.

Exact positioning of the log set is required in order to obtain a pleasing flame pattern and efficient combustion. Incorrect log placement may cause carbon build-up; excess thermal stress on the log set and stove parts, reduced efficiency, and high levels of carbon monoxide. If the log set does not set into the firebox exactly as outlined, contact your dealer for assistance.

Installation of the Log Set

(Refer to figure 7)

1) Using a 1/8" hex wrench, remove the screw in unit's doorknob. Once the front is open, remove the packaging material around the log set. Be careful not to damage the log set when unpacking.

2) Gently place the Rear Log in the firebox against the back wall, on the shelf against the back of the firebox, centered in the unit.

3) Gently place the Middle Log in the firebox. It should sit in the center of the burner tube. Leave a 1/2" gap between the front face of the log, and the burner tube. Center the log inside the firebox, keeping it parallel to the burner tube.

4) Place the Ember Screen (not shown) on the front burner tube with the long side of the Screen on the burner. This will allow the screen to hold the majority of the embers, which will be installed shortly.

5) Gently place the Front Left Log in the front of the firebox, keeping as far to the left as possible. Place the Right Front Log in the firebox. The Left and Right Front Logs should then be pulled together to meet in the center of the firebox to replicate one log. Pull the two as far forward as possible.

6) Spread randomly across the Ember Screen, the Charcoal Embers, giving preference to the rear of the front log. Leaving small gaps will create flames in that spot.

7) Gently place the Top Log (6) in the firebox

on the top of the Middle Log. The Middle and Rear Logs have posts, which slides into a hole on the underside of the Top Log.

8) With a 1/8" hex head wrench, use the bolt to fasten the door to the firebox. Make sure the door is properly secured to the firebox before turning the unit on. Be careful not to chip the enamel when fastening the door.

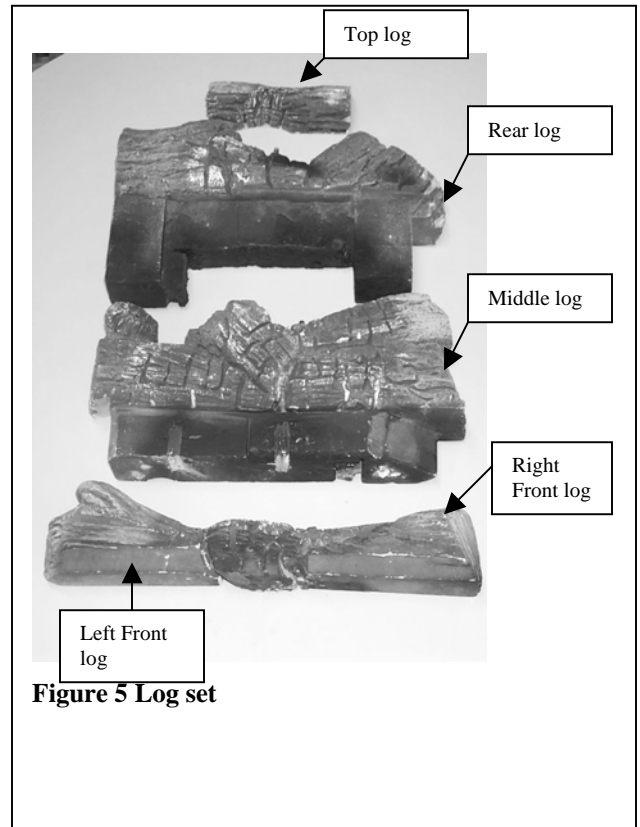

Figure 5 Log set

Removal of the Log Set

Remove the front screw using a 1/8" hex wrench and swing door open.

The log set is four pieces along with the charcoal embers as shown in *Figures 7*. First, remove the Top Log by pulling it up off the Middle Log and out of the firebox. Next remove the charcoal embers. Then lift upwards and pull the Front Log out of the Firebox. Next remove the Embers Screen from the burner tube. Grip the Middle Log and lift upward, off the burner tube holder, and out of the firebox. The Rear Log can then be removed from the firebox. Place the

logs and charcoal embers in a safe area where they will not be damaged.

CAUTION

Fragile! Handle log set and charcoal embers with care.

LIGHTING THE UNIT FOR THE FIRST TIME

SMOKE AND FUMES WARNING

When lit for the first time, the Santa Fe will emit some smoke and fumes. This is normal “off-gassing” of the paints and oils used in the manufacturing and assembly of the unit. Open windows to vent the room if necessary. The off gassing and fumes will subside after the first 10 to 20 minutes of operation.

Once the Santa Fe has been set in place and connected as described previously, the unit is ready to be lit for the first time. The manufacturer tests each Santa Fe prior to shipment, so ignition should take place without failure.

Caution

Log set and charcoal embers retain heat and can be very hot, if previously lit ! Allow 1 hour after pilot light is turned off before handling.

PILOT LIGHT

The Santa Fe has a piezoelectric spark igniter (the push button located next to the gas control valve behind the valve access door, which ignites the pilot light by means of a spark at the pilot light assembly. Do not attempt to light the

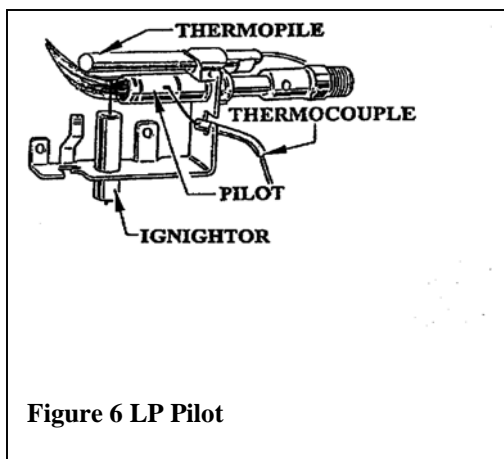

unit with a match or by any means than the piezoelectric spark.

PILOT ADJUSTMENT

The pilot light is preset by the manufacturer and should not need adjustment. The pilot light flame should be large enough to engulf the thermopile and thermocouple located next to the pilot, but not so large as to create excessive noise or consume excessive gas. (*refer to figures 8 & 9.* Note that the pilot flame must engulf the thermopile so that the thermopile can generate sufficient milli-voltage (325 to 500-mv) to power the millivolt gas control valve

Before lighting, smell all around the appliance area for gas. Be sure to smell next to the floor because some gases are heavier than air and will settle on the floor. If you smell gas, check for leaks. Use only your hand to turn the gas control knob. Never use tools.

WARNING

The control has an interlock device. If the stove has been lit, it will not relight immediately. After shutting off all gas flow, the pilot burner cannot be relit until the thermocouple has cooled, allowing the electromagnet to be released (*Approx. 60 sec.*). The gas control knob is designed to be operated by hand. Do not use any tools during this operation.

INITIAL ADJUSTMENTS

AIR SHUTTER

The air shutter is preset by the manufacturer for optimum operation and should not need adjustment. There is an adjustable air shutter located on the U-burner tube on the right rear of

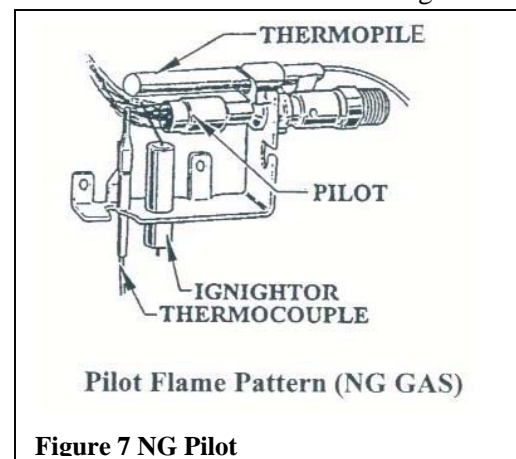

the unit under the air deflector. The air shutter is used to regulate the air-to-gas combustion mixture, which in turn adjusts the size and color of the flames. However, it may need adjustment once the unit has been installed to compensate for variations in supply line pressure, altitude, and other variables.

AIR SHUTTER ADJUSTMENTS

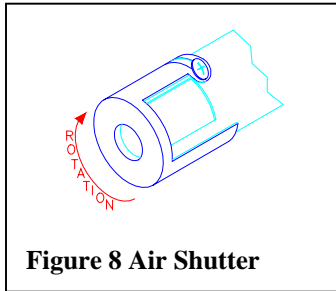
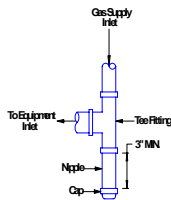

Figure 8 Air Shutter

Once the log set is removed, pull the burner tube up and towards the front of the firebox. The air shutter is factory set. *Only a Qualified Gas Technician should adjust the air shutter.*

The air shutter has one screw holding it in place as shown above. By loosening this screw, the shutter will rotate around the burner tube. Set the air shutter at the desired position and tighten the screw. Reposition the burner tube back into burner tube holder. Make sure the hole in the end of the air shutter is placed around the injector in the back corner of the firebox. Follow the Installation of the *Log Set on pages 11*.

The input rate of the heater can be verified by checking the manifold pressure. If the manifold pressure is correct, then the input rate is also correct. Be sure to check the manifold pressure and properly adjust the pilot and main burner flames.



ROUTINE MAINTENANCE AND CARE

The Santa Fe requires minimal routine maintenance and care. The unit should always be cool and off when being serviced.

Once a year the unit should be inspected by qualified service personnel to ensure that they are clean, prevent the accumulation of dust, lint and other debris, free of obstruction, safe and in good working condition.

To clean the firebox, set the switch to the “OFF” position, and turn off the gas at the gas control valve. When the unit is cool, open the front door and carefully remove the decorative ceramic fiber log set taking care not to damage the logs or chip the enamel cast iron. Clean the firebox burner tube and carefully vacuum the entire surface of the log set. Take care to thoroughly vacuum the ports (holes) along the top of the burner tubes. With the decorative ceramic fiber logs out of the firebox, fasten the door shut and light the unit according to *lighting instructions* described on *Page 4*. Check to ensure a flame is burning from each burner port. The pilot flame should be large enough to engulf the sensor/thermocouple. Turn the unit off by setting the switch to “Off”, and turning off the gas control valve. Allow the unit to cool. Check and clean any burner ports, which are not burning or not burning properly. Clean burner ports using a soft brush or vacuum cleaner. Adjust the pilot flame height if necessary. Complete the cleaning procedure by carefully placing the log set within the firebox as described on *Page 11*. Close and fasten the front door. Turn on the gas, light the unit and check for proper operation.

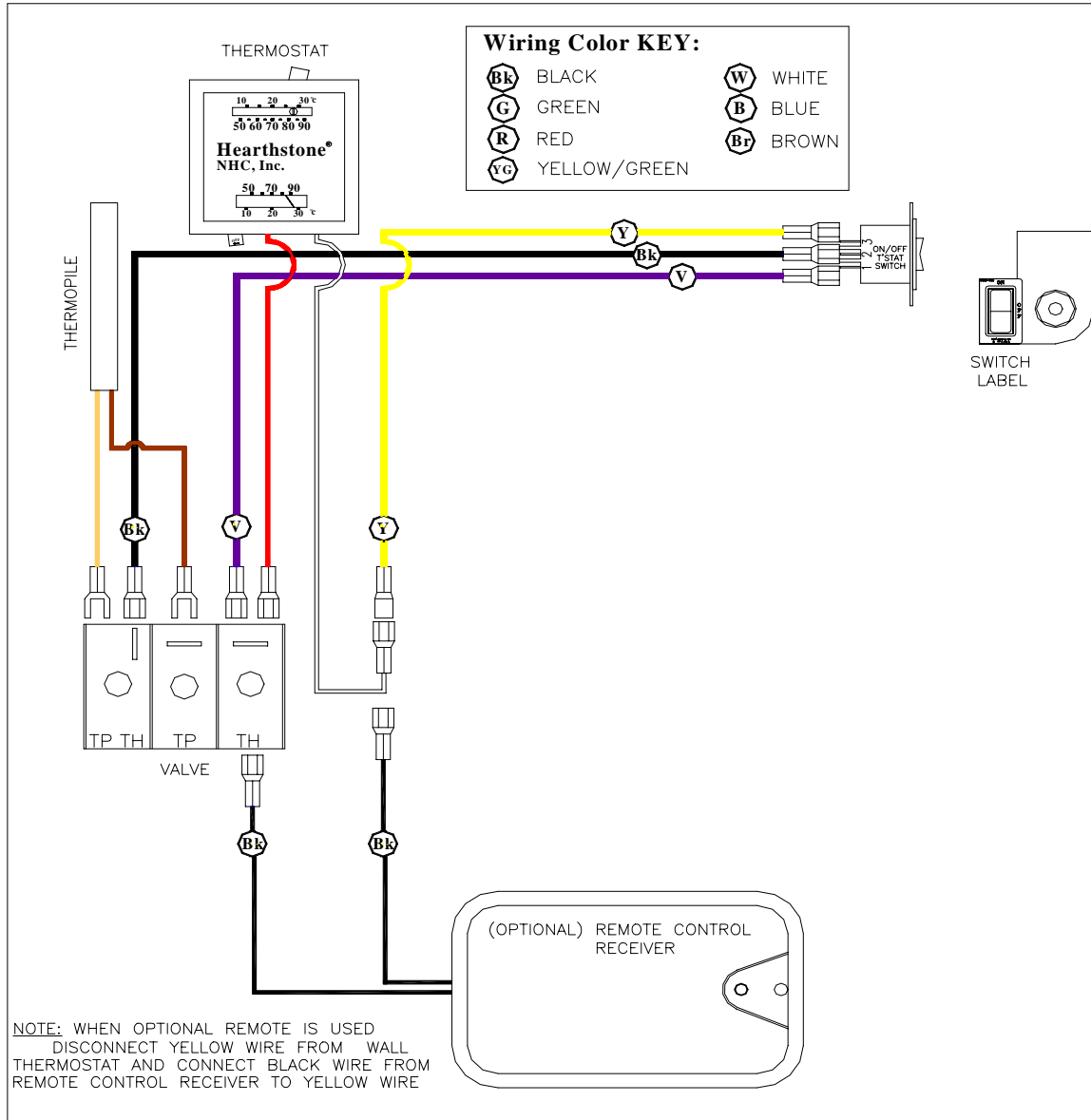

Figure 9 Wiring Diagram

WIRING INSTRUCTIONS

Caution: Label all wires prior to disconnection when servicing controls. Wiring errors can cause improper and dangerous operation. Verify proper operation after servicing.

PARTS LISTS

Part #	Description	Part #	Description
27x0-655	Door Handle	7211-301	Valve (NG)
27x0-650	Front Door	7211-370	Pilot Assembly (NG)
2710-810	Top Grill	7211-305	Valve (LP)
27x0-660	Front Grill	7211-327	Pilot Assembly (LP)
2710-630	Door Frame	7211-017	Gas Line 3/8 Diameter
2710-640	Screen Frame	7200-231	Burner Orifice (NG)(31)
2710-627	Exhaust Baffle	7200-249	Burner Orifice (LP)(49)
2710-600	Bottom	7211-008	Pilot Gas Tube
27x0-610	Ash Lip	7211-530	Rear Log
27x0-620	Left Side	7211-531	Middle Log
27x0-625	Right Side	7211-532	Right Front Log
27x0-670	Top	7211-534	Left Front Log
5780-010	Firebox	7211-533	Top Log
5780-050	Front Door Screen	7211-505	Charcoal Embers
5780-040	Burner Tube Holder	5300-095	Ember Screen
7211-248	Burner Tube	5710-131	Pilot Bracket
5780-020	Rear Heat Shield	5760-040	Front Door Hinge Bracket
5780-030	Valve Heat Shield	7210-103	Piezo Igniter
5300-066	Piezo Bracket	7211-430	Igniter Electrode

Accessories available:

REMOTE CONTROL ON/OFF #	(90-56912)
REMOTE CONTROL THERMOSTAT #	(90-56914)

WARNING

Do not substitute Materials. For replacement parts, or for information about parts or service, contact your authorized HearthStone retailer. For the name of the authorized retailer nearest to you, call (802) 888-5235

RATING LABEL



MODEL #
 SERIAL #

MODEL NAME: SANTA FE VENT FREE GAS HEATER
 LISTED GAS-FIRED VENT FREE FIREPLACE HEATER

KEEP BURNER AND CONTROL COMPARTMENT CLEAN. SEE INSTALLATION AND OPERATING INSTRUCTIONS ACCOMPANYING HEATER.

NOT FOR USE WITH SOLID FUEL

THIS APPLIANCE SHALL NOT BE INSTALLED IN A BEDROOM OR A BATHROOM
 THIS APPLIANCE IS APPROVED FOR MOBILE HOME INSTALLATION.

THIS APPLIANCE HAS BEEN MANUFACTURED WITH THE FOLLOWING GAS CONTROLS:

SIT NOVA 820 GAS CONTROL
 OP PILOT #8200/8400 SERIES

THIS APPLIANCE MUST BE INSTALLED IN ACCORDANCE WITH LOCAL CODES, IF ANY; IF NOT, FOLLOW THE CURRENT EDITIONS OF ANSI Z223.1 FOR MOBILE HOME INSTALLATION, INSTALL PER THE MANUFACTURED HOME CONSTRUCTION AND SAFETY STANDARD, TITLE 24 CFR, PART 3280

CAUTION: HOT WHILE IN OPERATION. DO NOT TOUCH. KEEP CHILDREN, CLOTHING, FURNITURE, GASOLINE AND OTHER LIQUIDS HAVING FLAMMABLE VAPORS AWAY

WARNING: IMPROPER INSTALLATION, ADJUSTMENT, ALTERATION, SERVICE OR MAINTENANCE CAN CAUSE PROPERTY DAMAGE, PERSONAL INJURY OR LOSS OF LIFE. REFER TO THE OWNER'S INFORMATION MANUAL PROVIDED WITH THIS APPLIANCE. INSTALLATION AND SERVICE MUST BE PERFORMED BY A QUALIFIED INSTALLER, SERVICE AGENCY OR THE GAS SUPPLIER.

THIS APPLIANCE IS ONLY FOR USE WITH THE TYPE OF GAS INDICATED ON THE RATING PLATE. THIS APPLIANCE IS NOT CONVERTIBLE FOR USE WITH OTHER GASES.

FUEL TYPE:	■ NG	■ LP
INPUT RATING (Btu/hr) 0-2000 ft	36,000	39,000
ORIFICE SIZE (DMS) 0-2000 ft	31	49
MANIFOLD PRESSURE - LO SETTING (in. w.c.)	1.6	6.4
MANIFOLD PRESSURE - HI SETTING (in. w.c.)	3.5	10.0
MINIMUM INLET PRESSURE (in.w.c.)	5.0	11.0
MINIMUM INPUT RATING (btu/hr)	24,000	31,000

MINIMUM CLEARANCES TO COMBUSTIBLES

EDGE OF UNIT TO BACK WALL 2"
 EDGE OF UNIT TO SIDE WALL 4"
 CORNER OF UNIT TO SIDE WALL (CORNER INSTALLATION) 2"

MANUFACTURED BY:



Date of Manufacture

2002	2003	2004	Jan	Feb	Mar	Apr	May	Jun	Jul	Aug	Sep	Oct	Nov	Dec
■	■	■	■	■	■	■	■	■	■	■	■	■	■	■

REMOVAL OF THIS MARKING WILL VOID THE COMPLIANCE OF THIS HEATER WITH ANSI Z21.11.2.

MADE IN USA

3300-561

HEARTHSTONE GAS-FIRED STOVE AND INSERT LIMITED WARRANTIES

These warranties give you specific legal rights. You may also have other rights which vary from State to State.

HearthStone Quality Home Heating Products, Inc. (HearthStone) warrants **to the original purchaser only** (the “Original Purchaser”) the new gas-fired stove/insert manufactured by HearthStone and purchased by the Original Purchaser (referred to as the “Stove” for simplicity) against any of the occurrences listed in this document that result from defects in material or workmanship. All obligations of HearthStone under this document commence on the date the Original Purchaser purchases the Stove (the “Purchase Date”).

LIMITED LIFETIME WARRANTY

HearthStone warrants the following parts of the Stove against the following occurrences that result from defects in material and workmanship:

- All cast iron parts, including the cast iron heat exchanger – against breakage, cracking or burn-through.
- All stones – against cracking or breakage due to thermal stress, **excluding** surface and hairline cracks and scratches that do not affect the operation or safety of the Stove.
- Glass – against breakage due to thermal shock.

LIMITED FIVE-YEAR WARRANTY

HearthStone warrants the following parts of the Stove against the following occurrences that result from defects in material and workmanship:

- Firebox and firebox baffle – against breakage, cracking or burn-through.
- Convective heat exchanger – against breakage, cracking or burn-through.
- Burners, air shutters and orifices – against breakage, cracking or burn-through.
- Ceramic logs and embers – against breakage, cracking or burn-through.

This warranty expires on the fifth (5th) anniversary of the Purchase Date.

LIMITED THREE-YEAR WARRANTY

HearthStone warrants the following parts of the Stove against the following occurrences that result from defects in material and workmanship:

- Gas train, including gas valve, millivolt wiring, spill switch, pilot assembly, thermopile, thermocouple, piezo igniter, and, if the Stove is a vent-free model, ODS system – against breakage or malfunction.

This warranty expires on the third (3rd) anniversary of the Purchase Date.

LIMITED ONE-YEAR WARRANTY

HearthStone warrants the following parts of the Stove against the following occurrences that result from defects in material and workmanship:

- Enamel Finish – against peeling or fading, **excluding** chipping, mechanical abrasion, chemical abrasion or crazing.
- Gaskets and sealants – against breakage or deterioration.
- Accessories and electrical components such as blowers, switches and thermo discs, **excluding** venting components, hearth components, electrical components and other components or accessories used in conjunction with the installation of the Stove ***not*** manufactured or supplied by HearthStone – against breakage or malfunction.

This warranty expires on the first (1st) anniversary of the Purchase Date.

EXCLUSIONS

The warranties contained in this document do not cover, nor is HearthStone responsible for:

1. Damage resulting from installation or operation of the Stove in a manner contrary to the owner's manual.
2. Damage or non-performance resulting from faulty or incomplete setup, installation and start-up or mishandling, abuse, or misuse of the Stove, including but not limited to over-firing.
3. Damage resulting from installation, modification, alteration, repair or service of the Stove by any party other than HearthStone or an authorized HearthStone dealer (a "Dealer").
4. Damage due to water or due to installation of the Stove in a damp or high condensation area.
5. Damage due to installation of the Stove in an atmosphere contaminated by damaging chemicals, including but not limited to chlorine, fluorine or salts.
6. Scratches on glass, enameled surfaces or stones due to mechanical abrasion.
7. Standard wear and tear of the Stove resulting from normal usage over time.
8. Damage, operational-related problems, or inadequate performance caused by site, installation or environmental conditions beyond HearthStone's control, including but not limited to nearby trees, rooftops, buildings, wind, hills, mountains, inadequate or excessive venting, insufficient make up air, or negative air pressure whether or not caused by mechanical systems such as furnaces, exhaust fans, clothes dryers, etc.
9. A defect in any part of the Stove if the Original Purchaser fails to comply with HearthStone's or a Dealer's request to ship the part or the Stove to HearthStone or a Dealer, as the case may be.

THE WARRANTIES CONTAINED IN THIS DOCUMENT ARE EXCLUSIVE AND ARE GIVEN BY HEARTHSTONE AND ACCEPTED BY THE ORIGINAL PURCHASER IN LIEU OF ALL OTHER EXPRESS WARRANTIES AND ANY OBLIGATIONS, LIABILITIES, RIGHTS, CLAIMS, OR REMEDIES IN CONTRACT OR TORT, WHETHER OR NOT ARISING FROM HEARTHSTONE'S NEGLIGENCE, ACTUAL OR IMPUTED. ALL IMPLIED WARRANTIES, INCLUDING THE WARRANTIES OF MERCHANTABILITY AND FITNESS FOR A PARTICULAR PURPOSE, ARE GIVEN **ONLY** TO THE EXTENT REQUIRED BY FEDERAL OR STATE LAW. EXCEPT AS OTHERWISE REQUIRED BY STATE LAW, UPON THE EXPIRATION OF THE EXPRESS LIMITED WARRANTIES CONTAINED HEREIN, **NO** IMPLIED WARRANTIES, INCLUDING THE IMPLIED WARRANTIES OF MERCHANTABILITY OR FITNESS FOR A PARTICULAR PURPOSE, SHALL APPLY TO THE SUBJECT STOVE. **SOME STATES DO NOT ALLOW LIMITATIONS ON HOW LONG AN IMPLIED WARRANTY LASTS, SO THE ABOVE LIMITATION MAY NOT APPLY TO YOU.**

THE WARRANTIES CONTAINED IN THIS DOCUMENT EXTEND **ONLY** TO THE ORIGINAL PURCHASER OF THE WOODSTOVE WARRANTED HEREUNDER. THEY DO NOT EXTEND TO ANY SUBSEQUENT OWNERS.

UNDER NO CIRCUMSTANCES SHALL HEARTHSTONE BE LIABLE TO THE ORIGINAL PURCHASER OR ANY OTHER PERSON FOR ANY INCIDENTAL OR CONSEQUENTIAL DAMAGES, INCLUDING BUT NOT LIMITED TO DAMAGE TO PROPERTY OR PERSONAL INJURIES, WHETHER ARISING OUT OF BREACH OF WARRANTY, TORT, OR OTHERWISE, EVEN IF HEARTHSTONE HAS BEEN APPRAISED OF THE POSSIBILITY OF SUCH DAMAGES. **SOME STATES DO NOT ALLOW THE EXCLUSION OR LIMITATION OF INCIDENTAL OR CONSEQUENTIAL DAMAGES, SO THE ABOVE LIMITATION OR EXCLUSION MAY NOT APPLY TO YOU.**

QUALIFYING FOR WARRANTY COVERAGE

To obtain performance of any obligation under this document, the Original Purchaser must, **within the applicable warranty time period**, contact HearthStone, at the address listed in the Warranty Registration section below or at **(802) 888-5235**, or a Dealer for instructions regarding the return of defective parts for repair, the return of the Woodstove for repair, or a Dealer service call. The Original Purchaser should refer to the Dealer network search engine contained on HearthStone's Web site (www.hearthstonestoves.com), or call HearthStone at (802) 888-5235, to find a Dealer nearest the Original Purchaser's location.

REMEDY The remedy for any breach of the foregoing warranties will consist of repair or replacement, at HearthStone's option, of any covered defect in the Stove. When the Original Purchaser contacts HearthStone or a Dealer, HearthStone or the Dealer, as the case may be, will instruct the Original Purchaser to **either** return the defective part, or the entire Stove (if needed), with shipping prepaid, to HearthStone or a Dealer **or** allow a Dealer to make a service call at the place where the Stove is located. In the event the Original Purchaser refuses to allow a Dealer to make a service call, HearthStone or a Dealer, as the case may be, will request that the Original Owner return the defective part, or the entire Stove (if needed), with shipping prepaid, to HearthStone or a Dealer. **Notwithstanding any other provision of this document, the Original Purchaser shall pay for any travel fees and service charges related to a Dealer's service call.**

Parts: HearthStone will replace defective parts covered by the foregoing warranties at no charge.

Labor: Within the first (1st) year after the Purchase Date, HearthStone will pay for warranty labor performed by a Dealer at HearthStone's published labor rates in effect at the time the labor is performed. Thereafter, the Original Purchaser is responsible for the cost of labor.

Shipping cost for parts: Within the first ninety (90) days after the Purchase Date, HearthStone will pay for the shipping of Stove parts covered by any of the foregoing warranties to and from HearthStone or a Dealer, as the case may be. Thereafter, the Original Purchaser is responsible for all shipping costs related to shipping Stove parts to and from HearthStone or a Dealer, as the case may be.

Shipping cost for the Stove: Within the first (1st) year after the Purchase Date, if the Original Purchaser is instructed to return the Stove to HearthStone or a Dealer for repair, HearthStone will pay fifty percent (50%) and the Original Purchaser will pay fifty percent (50%) of the shipping costs related to shipping the Stove to and from HearthStone or a Dealer, as the case may be. Thereafter, the Original Purchaser is responsible for one hundred percent (100%) of all of the shipping costs related to shipping the Stove to and from HearthStone or a Dealer, as the case may be. Notwithstanding any other provision of this document, in no event will HearthStone pay for any Dealer fees or other fees for pick up or delivery of the Stove returned for repair; the Original Purchaser shall be responsible for any such fees.

WARRANTY REGISTRATION

The Original Purchaser may send a completed and signed Warranty Registration Form, which is enclosed in the Stove warranty packet, to the following address:

HearthStone Quality Home Heating Products, Inc.
Warranty Department
317 Stafford Avenue
Morrisville, VT 05661

NOTE: SENDING IN THE SIGNED WARRANTY REGISTRATION FORM IS *NOT* A CONDITION OF WARRANTY COVERAGE OR HEARTHSTONE'S PERFORMANCE.