

Owner's Manual & Installation Guide

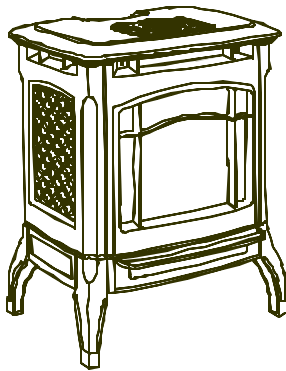

for the **Stowe** (8321) GAS-FIRED
DIRECT-VENT HEATER



READ THIS OWNER'S MANUAL

Operate and maintain this gas heater according to this instruction manual.

Read This Manual In Its Entirety.

WARNING: If the information in these instructions is not followed exactly, a fire or explosion may result causing property damage, personal injury, or loss of life.

Do not store or use gasoline or other flammable vapors and liquids near this or any other gas appliance.

WHAT TO DO IF YOU SMELL GAS:

- Do not try to light any appliance.
- Do not touch electrical switches; do not use the phone in your building.
- Immediately call your gas supplier from a neighbors phone. Follow your gas supplier's instructions.
- If you cannot reach your gas supplier, call the fire department.

A qualified installer, service agency or gas supplier must perform installation and service. In the Commonwealth of Massachusetts, all installation of gas lines and gas fitting shall only be done by a licensed gas fitter or licensed plumber.

AVERTISSEMENT: Assurez-vous de bien suivre les instructions donné dans cette notice pour réduire au minimum le risque d'incendie ou pour éviter tout dommage matériel, toute blessure ou la mort.

Ne pas entresposer ni utiliser d'essence ni d'autre vaperurs ou liquides inflammables dans le voisinage de cet appareil ou de tout autre appareil.

QUE FAIRE SI VOUS SENTEZ UNE ODEUR DE GAZ:

- Ne pas tenter d'allumer d'appareil.
- Ne touchez à aucun interrupteur. Ne pas vous servir des téléphones se trouvant dans le bâtiment où vous vous trouvez.
- Appelez immédiatement votre fournisseur de gaz depuis un voisin. Suivez les instructions du fournisseur.
- Si vous ne pouvez rejoindre le fournisseur de gaz, appelez le service des incendies.

L'installation et service doit être exécuté par un qualifié installer, agence de service ou le fournisseur de gaz.

HearthStone Quality Home Heating Products, Inc.
317 Stafford Avenue,
Morrisville, Vermont 05661-8695
E-Mail: inquiry@hearthstonestoves.com



6400-40422

11-24-04

INFORMATION SHEET

Use this page to record all relevant information concerning the purchase, installation, and maintenance of your STOWE Gas-Fired Direct-Vent heater. This information will facilitate servicing, purchase of replacement parts, and warranty claims (if necessary). Keep your original receipt in a safe place as proof of purchase.

Serial Number: _____

Fuel type (check one) _____ Natural Gas _____ Liquid Propane

Sold by: _____

Phone: _____ Date of Purchase: _____

Installed by: _____

Phone: _____ Date of Installation: _____

Gas Supplier: _____

Phone: _____

Read this Owner's Manual before installing or operating the STOWE heater. Retain this manual for future reference.

SERVICE RECORD

Date	Who Performed Work	Work Performed	Notes:

WHAT
Firebox Cleaning.....
Glass Cleaning.....

WHEN
annually
as needed

WHAT
Door Gasket.....
WHEN
Replacement as needed

INTRODUCTION

Congratulations on your purchase of a Stowe Gas-Fired Direct-Vent heater. The Stowe, by HearthStone, incorporates the latest in balanced vent gas technology, which will provide you with clean, efficient heat for years to come. The cast iron gives the Stowe a pleasing look that is maintained with minimum care.

The Stowe will provide you with years of practical and convenient service. However, as with any gas appliance, the unit must be properly installed and maintained by qualified service personnel to ensure safe and trouble-free operation.

Your Stowe is equipped with a standing pilot which:

1. Generates a milli-volt signal that powers (opens) the millivolt gas valve.
2. Lights the main burner when the thermostat calls for heat.

This unit is equipped with an On/Off/T'stat switch and a variable output control. The variable output control is located on the gas control valve. It allows you to vary the heat output, along with the flame height to suit personal taste. Heat output can be reduced {set to "LOW"} during the Fall and Spring, when the need for heat is reduced and increased {set to "HIGH"} during Winter months, when the need for heat is the greatest.

A wall-mounted thermostat is provided by HearthStone. Regardless of how you set the variable output control, when the optional thermostat has been installed and the On/Off/T'stat switch is set to "T'stat", the wall-mounted thermostat will control the on/off cycling of the unit. At any time, you can override the thermostat with the

On/Off/T'stat switch by setting it to "ON" or "OFF".

The Unit can also be equipped with an optional blower-fan kit which operates independently of the thermostat. The fan switch allows you to turn the fan on or off and control the speed of the fan to suit your needs. The fan will automatically turn on when the stove is hot and cycle off when the unit is no longer hot.

Also available are two different optional remote controls. Both of the remote controls are capable of turning the unit on and off. One of the optional remotes also allows you to control the temperature of the room from anywhere in the vicinity of the unit. If "ON" & "OFF" are the only controls required; Kit # 90-56912 can be used. If you would like to control the temperature via the remote control, use Kit # 90-56914.

READ THIS OWNER'S MANUAL

Operate, and maintain, this gas heater according to the instructions in this manual. For your safety, and years of trouble free operation, read this manual in its entirety.

THIS HEATER MUST BE INSTALLED AND MAINTAINED BY QUALIFIED SERVICE PERSONNEL

Verify the gas connections and venting systems with requirements of local, regional or national installation codes. Qualified service personnel must inspect the gas heater before use, and at least annually.

TABLE OF CONTENTS

INTRODUCTION.....	3
SAFETY INFORMATION.....	4
SPECIFICATIONS:.....	7
OWNER'S INFORMATION.....	8
INSTALLER'S INFORMATION.....	8
ITEMS REQUIRED FOR INSTALLATION.....	9
UNPACKING AND INSPECTION.....	9
VENTING INFORMATION.....	13
ELECTRICAL CONNECTIONS.....	21
GAS SUPPLY & CONNECTIONS.....	23
LOG PLACEMENT.....	24
LIGHTING THE UNIT FOR.....	26
THE FIRST TIME.....	26
INITIAL ADJUSTMENTS.....	27
ROUTINE MAINTENANCE AND CARE.....	31
PARTS LISTS.....	33
LIMITED WARRANTIES.....	38

SAFETY INFORMATION

Your Stowe is a very attractive and extremely efficient, utilizing today's best technologies. By following a few simple safety precautions and by performing minimal maintenance, the unit will remain appealing while providing years of quality performance.

The installation must conform to local codes or, in the absences of local codes, the current National Fuel Gas Code, ANSI Z223.1 (NFPA 54) or CAN/CGA B149 Installation Code. (*Installer l'appareil selon les codes ou*

réglements locaux, ou, en l'absence de tells règlements, selon les Codes d'installation CAN/CGA B149.)

Do not use this appliance if any gas control part was under water. Immediately call a qualified service technician to inspect the heater and to replace any part of the control system and gas control that was submerged. (*Ne pas se servir de cet appareil s'il a été plongé dans l'eau, complètement ou en partie. Appeler un technicien qualifié pour inspecter l'appareil et remplacer toute partie du système de contrôle et toute commande qui ont été plongés dans l'eau.*)

During the first few hours of operation, the appliance may produce a slight smoke and/or odor. This is normal during the first several burns. During the initial burn, open a window(s) to assist in the removal of the smoke/odor. If the logs appear to smoke, turn the heater off and call a qualified service technician.

The appliance and its individual shutoff valve must be disconnected from the gas supply piping system during any pressure testing of that supply system at test pressures in excess of ½ psig. (3.5k Pa).

FIRE HAZARD

Do not store or use gasoline or other flammable vapors or liquids in the vicinity of this appliance. The Stowe should be located out of traffic and away from furniture, draperies, clothing, and flammable material.

SHOCK HAZARD

(When equipped with an optional blower)
This appliance is equipped with a three-prong (grounding) plug for protection against shock hazard, and should be plugged directly into a properly grounded three-prong receptacle. Do not cut, or remove, the grounding prong from the plug.

MUST BE VENTED TO THE OUTSIDE

Never vent the gas heater to other rooms, or buildings. This gas appliance must not be connected to a chimney flue serving a separate solid-fuel burning appliance.

SERVICE CAUTION

If you believe your Stowe is not performing properly, in any way, immediately discontinue operation until the unit is inspected, and approved for use by qualified service personnel. Prior to servicing the unit, turn the valve control knob clockwise to “OFF”. The unit should be cool prior to servicing and cleaning. Any safety screen, guard, or component removed during servicing must be replaced before operation. Use of any components not supplied by HearthStone voids all warranties. **Do not substitute components.**

HOT SURFACES

Certain exposed surfaces of the Stowe will reach high temperatures during normal operation. Clearances to combustibles must be maintained, as specified in the “Clearances To Combustibles” section of this manual. **Due to high temperatures, the appliance must be located out of traffic and away from furniture, draperies, clothing, and flammable materials. Alert children, and adults, to the hazards of high surface temperatures, and that they should stay away to avoid burns to skin or possible clothing ignition. Carefully supervise young children when in the same room as the appliance. Do not place clothing, or other flammable material, on or near, the appliance.** (*Surveille les enfants. Garder les vêtements, les meubles, l'essence ou autres liquides à vapeur inflammables loin de l'appareil.*)

Clean the area around, under, and behind the unit on a regular basis to prevent the accumulation of dust and lint.

NEVER BURN PAPER, WOOD OR OTHER MATERIALS

This gas heater is designed to burn natural gas, or liquid propane (LP). Never burn any fuel not intended for use with this unit.

- **WARNING! This gas appliance must not be connected to a chimney flue serving a separate solid-fuel burning appliance**
- **WARNING! Do not operate the appliance with the front glass removed, cracked, or broken. Replacement of glass must be done by a licensed, or qualified, service person. Only open front for routine service. Do not slam or strike glass.**

CERAMIC LOG SAFETY INFORMATION

If the decorative ceramic log material supplied with the Stowe is damaged, or missing, it must be replaced with the same, approved replacement parts supplied by HearthStone. These components affect the combustion quality, and safety of the heater. Do not replace ceramic logs with unapproved ceramic logs, or any other material.

Always wear gloves and safety goggles while handling the log set and ember materials.

ELECTRICAL HAZARD!

When the optional blower kit is installed, the Stowe must be electrically grounded in

accordance with local codes, or in the absence of local codes, with the National Electrical Code, ANSI.NFPA 70 in the U.S. or CSA C22.1 Canadian Electrical Code in Canada. The three-prong grounded plug must be plugged directly into a properly grounded three-prong receptacle. Do not cut, or remove, the grounding prong from the plug or otherwise attempt to circumvent the grounding protection provided with the unit.

DO NOT LIGHT PILOT OR PAN BURNER BY HAND

The standing pilot light on this gas heater is lit by using a piezoelectric spark generator as described elsewhere in this manual. Never attempt to light the pilot, or main burner, by hand with a match or lighter. If, after repeated attempts, the pilot light fails to light, discontinue operation; turn off the gas at the gas control valve, and immediately contact qualified service personnel for assistance.

Certified for use by:

Board of State Examiners of Plumbers and Gasfitters
100 Cambridge Street, Room 1511
Boston, Massachusetts 02202

Mobile Home Installations

This appliance may be installed in an aftermarket, permanently located, manufactured (mobile) home, where not prohibited by local codes.

This appliance is only for use with the type(s) of gas indicated on the rating plate. This appliance is not convertible for use with other gases, unless a certified kit is used.

(Cet appareil peut être installé dans un maison préfabriquée (mobile) déjà installée à demeure si les règlements locaux le permettent.

Cet appareil doit être utilisé uniquement avec les types de gas indiqués sur la plaque signalétique. Ne pas l'utiliser avec d'autres gas sauf si un kited conversion certifié est installé.)

SERVICE CAUTION

Replace any shield, door, or safety screen component removed for servicing prior to operating the stove. If you believe your Stowe is not performing properly in any way what so ever; immediately discontinue operation until qualified service personnel have inspected the unit. Always shut off the gas, and electricity (if equipped), to the stove while servicing, or cleaning. Use of any components not supplied, or specified by HearthStone on the stove or vent system voids all warranties. **Do not substitute components.**

SPECIFICATIONS:

LISTED: Gas-Fired Direct-Vent Fireplace Heater

Model: Stowe Direct-Vent Gas Fireplace Heater (8321)

Testing Agency: Intertek Testing Services NA, Inc. (ITS)

Tested to: ANSI Z21.88-2002, CSA 2.33-M02, CAN/CGA2.17-M91
 Certified for Canada, CSA P.4.1

Approved for Mobile Home Installation (see page 6)

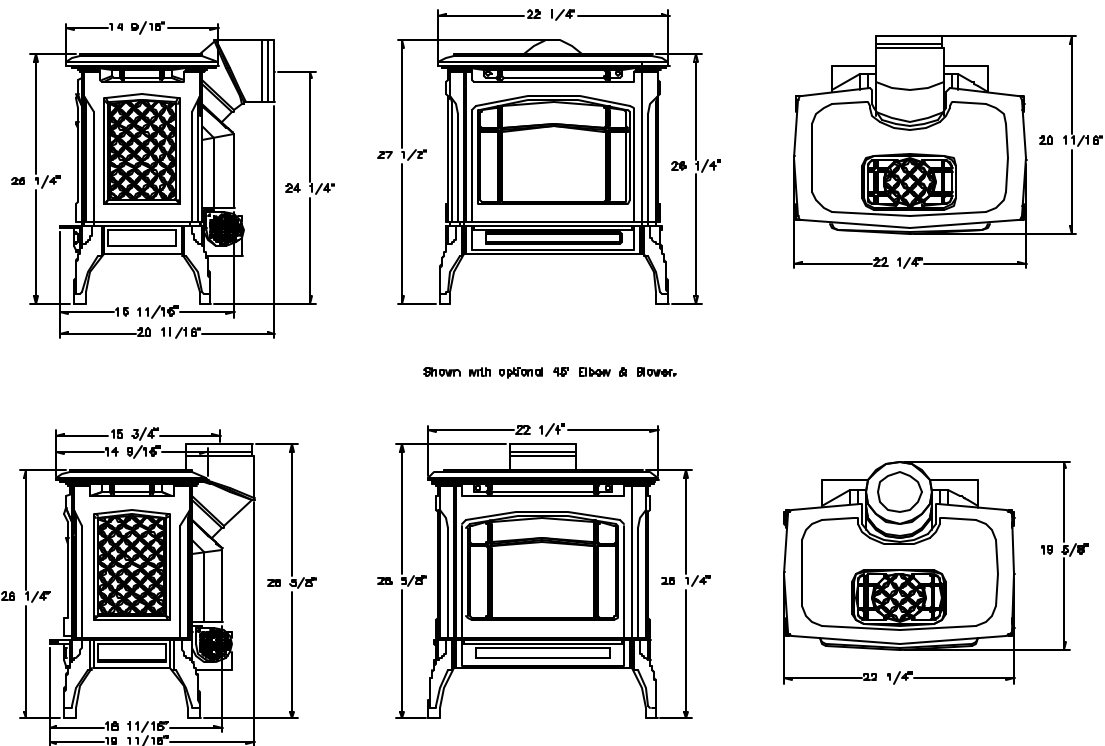

Figure 1: Stowe Dimensions

FUEL TYPE:	NG	LP
INPUT RATING (Btu/hr) 0-2000 ft	26,000	26,000
INPUT RATING (Btu/hr) 2000-4500 ft	25,500	25,500
ORIFICE SIZE (DMS) 0-2000 ft	40	53
ORIFICE SIZE (DMS) 2000-4500 ft	41	54
MANIFOLD PRESSURE - LO SETTING (in. W.c./kpa)	1.2/0.3	3.3/0.8
MANIFOLD PRESSURE - HI SETTING (in. W.c./kpa)	3.5/0.87	10.0/2.48
INLET PRESSURE - LO (in.w.c./kpa)	5.0/1.24	11.0/2.88
INLET PRESSURE - HI (in.w.c./kpa)	7.0/1.74	13.0/3.22
MINIMUM INPUT RATING (btu/hr)	15,600	15,600
MAXIMUM OUTPUT (btu/hr) 0-2000 ft	18,100	18,100

OWNER'S INFORMATION

The installation must conform with local codes or, in the absence of local codes, the current National Fuel Gas Code, ANSI Z223.1 (NFPA 54) or CAN/CGA B149 Installation Code. *(Installer l'appareil selon les codes ou règlements locaux, ou, en l'absence de tels règlements, selon les Codes d'installation CAN/CGA-B149.)* **Do not use this appliance if any gas control part was under water. Immediately call a qualified service technician to inspect the heater, and to replace any part of the control system and gas control that was submerged.** *(Ne pas se servir de cet appareil s'il a été plongé dans l'eau, complètement ou en partie. Appeler un technicien qualifié pour inspecter l'appareil et remplacer toute partie du système de contrôle et toute commande qui ont été plongés dans l'eau.)*

DAILY OPERATION

The Stowe gas-fired heater is operated easily by the homeowner once it is installed and adjusted by qualified service personnel. The unit is controlled via the wall-mounted thermostat during the heating season. Set the thermostat to the desired room temperature and the unit will cycle on and off as required. By adjusting the variable output control located on the gas control valve, the rate of heat output can be varied to meet the heating requirements of the season. Choosing a low flame setting will result in longer burn cycles at a reduced output, while choosing a high flame setting will result in a shorter, hotter burn cycle. Through trial and error, the homeowner can select the optimum flame size for their setting, and application.

During the summer non-heating season, switch the wall thermostat to "OFF", and turn off the pilot by turning the gas control to "OFF". This will improve the overall efficiency of the unit as the heat from the pilot is wasted. When putting the unit back

into service, follow the lighting instructions described on page 28.

When the unit is first lit, especially when cool, it is normal to experience some condensation on the inside of the window glass. This condensation will evaporate within the first few minutes of operation. If continuous condensation is observed on the window glass, or dripping water is seen coming from any part of the unit or venting system (chimney), immediately discontinue operation of the unit, and contact qualified service personnel.

INSTALLER'S INFORMATION CODES

Adhere to **all** local codes or, in their absence, the latest edition of THE NATIONAL FUEL GAS CODE ANSI Z223.1 (NFPA 54) or CAN/CGA B149 Installation Code that can be obtained from:

**AMERICAN NATIONAL STANDARDS
INSTITUTE, INC.**
1430 BROADWAY
NEW YORK, NY 10018
OR
**NATIONAL FIRE PROTECTION
ASSOCIATION, INC.**
BATTERY MARCH PARK
QUINCY, MA 02269

The appliance when operated with a blower installed, must be electrically connected and grounded in accordance with local codes or, in the absence of local codes, with the current NFPA 70-National Electrical Code or CSA C22.1-Canadian Electric Code.

A manufactured home (mobile) OEM installation must conform with the Manufactured Home Construction and

Safety Standard, Title 24 CFR, Part 3280 (U.S.) or Standard for Manufactured Home Installation, ANSI/NCBCS A225.1 or Standard for Gas Equipped Recreational Vehicles and mobile Housing, CSA Z240.4.CAN/SCA Z240 MH (Canada). (*Installer l'appareil selon les codes ou règlements locaux, ou, en l'absence de tels règlements, selon les Codes d'installation CAN/CGA-B149.*)

For installations from 610-1370 meters (2000-4500 ft.) the orifice sizes (DMS) for natural and propane gas are 41 and 54 respectively. See data plate for additional information. For high altitude installations consult the local gas distributor or the authority having jurisdiction for proper rating methods. If the installer must convert the unit to adjust for varying altitudes, the information sticker must be filled out by the installer, and adhered to the appliance at the same time of conversion. (*Cet appareil est équipé pour des altitudes comprises entre 0 et 2000 pieds (0-610 m) seulement.*)

ITEMS REQUIRED FOR INSTALLATION

- * External regulator (for propane/L.P.G. only)
- * Piping which complies with local codes
- * Pipe sealant approved for use with propane/L.P.G. (resistant to sulfur compounds)
- * Manual shutoff valve
- * Sediment trap (see page 24)
- * Tee joint
- * Pipe wrench
- * Phillips head screwdriver
- * 7/16-inch wrench
- * Other parts as required by local code
- * Safety Glasses
- * Gloves

PACKING LIST

- 1-Stowe Gas-Fired Heater
- 4-Decorative Ceramic Logs
- 1-Bag Charcoal Embers Only
- 1-Bag Charcoal Embers and "Rock Wool"
- 1-Owner's Manual

- 1-Thermostat
- 1-40' Thermostat wire
- 1-L.P. Fuel Conversion Kit
- 1-Warranty Validation Form
- 1-Exhaust Restrictor Plate with Mounting Screw

Note: Vent kits and components are supplied separately. Failure to use the venting components suggested by HearthStone will void your warranty.

UNPACKING AND INSPECTION

Unpack and Inspect for Damage

The Stowe is packaged by HearthStone to withstand normal shipment without damage. However, damage can still occur during transit; so take care to inspect for damage when unpacking and installing the unit. If any damage, or missing parts are detected, immediately contact your dealer.

Do not install, or put into service, a damaged or incomplete heater.

Caution: The top grill is NOT cemented, or otherwise permanently fastened in place! We recommend your Stowe be moved into place, venting attached, gas and electrical connections made, and any accessory blower installed before installing the top grille.

Inspect the Stowe for visible or concealed damage. The unit should appear to be square and true. The sheet metal parts should be smooth and free of bends and dents. The enameled cast iron should be free of chips or cracks. If visible or concealed damage is found, or suspected, contact your dealer for instructions.

With the accessory box removed and set aside, undo the lag bolts that fasten the unit to the pallet. Take care not to mar or chip the enameled legs. Have someone help lift the stove off the pallet and set it into place.

The decorative ceramic logs supplied with the Stowe are contained within the firebox. Always use great care when handling the decorative ceramic fire logs, as they are fragile and subject to damage and breakage if handled roughly. Open the firebox door and inspect the logs for damage. If a broken log is encountered, contact your dealer for replacement logs. Otherwise, set the logs aside until called for during the installation.

HEARTH REQUIREMENT/FLOOR PROTECTION

The Stowe may be placed on a non-combustible surface or wood floor. For placement of the Stowe on carpeting, vinyl tile or other combustible materials, the appliance must be installed on a metal or wood panel extending the full width and depth of the appliance. Installations must meet local codes.

CLEARANCE TO COMBUSTIBLES

Due to high surface temperatures, the unit should be located out of traffic, and away from furniture and draperies. Clothing and other flammable material should not be placed on or near the heater. When positioning the unit always maintain adequate clearances around air openings into the combustion chamber and allow for adequate ventilation. Minimum clearances to combustibles must be maintained as shown in the illustrations on page 12.

Note: The rear clearance to combustibles will be determined by either the unit's or the vent pipe's minimum clearance, depending on whether the installation calls for vertical rise within the room or a rear exit, through-the-wall vent pipe.

Be sure to consider the need for access to the gas control valve access door on the front of the unit as well as full access for

periodic cleaning and servicing. Also consider the location of the Optional Blower Fan.

- **Caution:** These clearances represent *minimum* distances in all cases, which, through testing in an independent laboratory to ANSI and CSA standards, will prevent fire or spontaneous combustion. We do not control the combustible materials exposed to heat by this product; therefore, an assessment must be made by the installer to prevent consequential damage of walls and flooring.

The corner clearance for the Stowe is 2" to be measured from the edge of the top castings, to the adjacent wall.

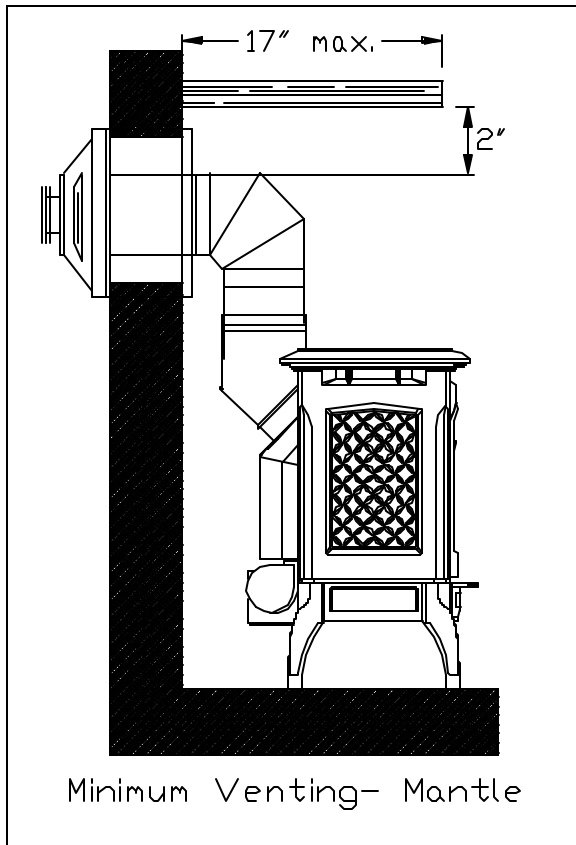

Figure 2: Minimum Venting-Mantle Clearance To Combustibles

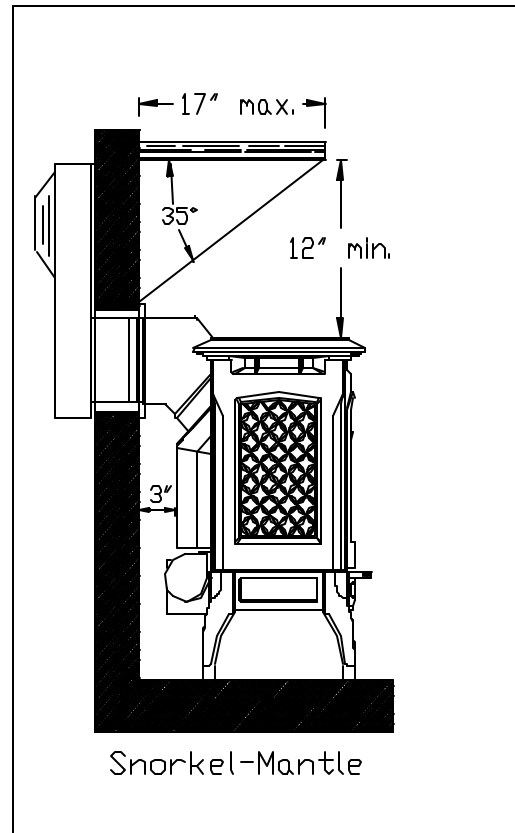

Figure 4: Snorkel-Mantle Clearance To Combustibles

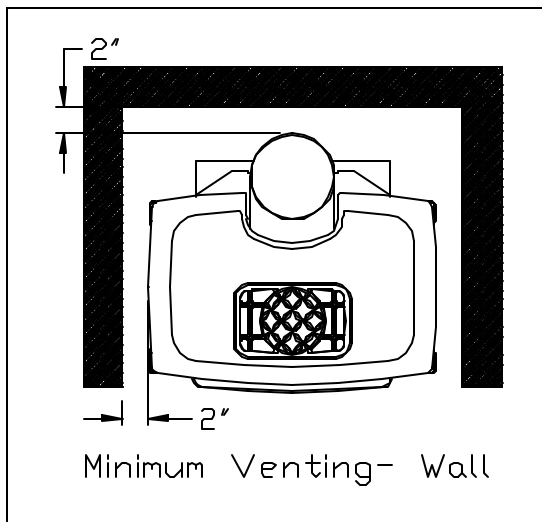

Figure 3: Minimum Venting-Wall Clearance To Combustibles

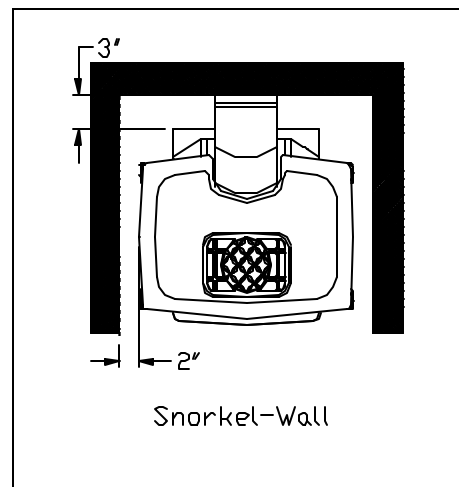

Figure 5: Snorkel-Wall Clearance To Combustibles

The corner clearance for the Stowe is 2” to be measured from the edge of the top castings, to the adjacent wall.

Acceptable Direct-Vent TERMINATION Cap locations.

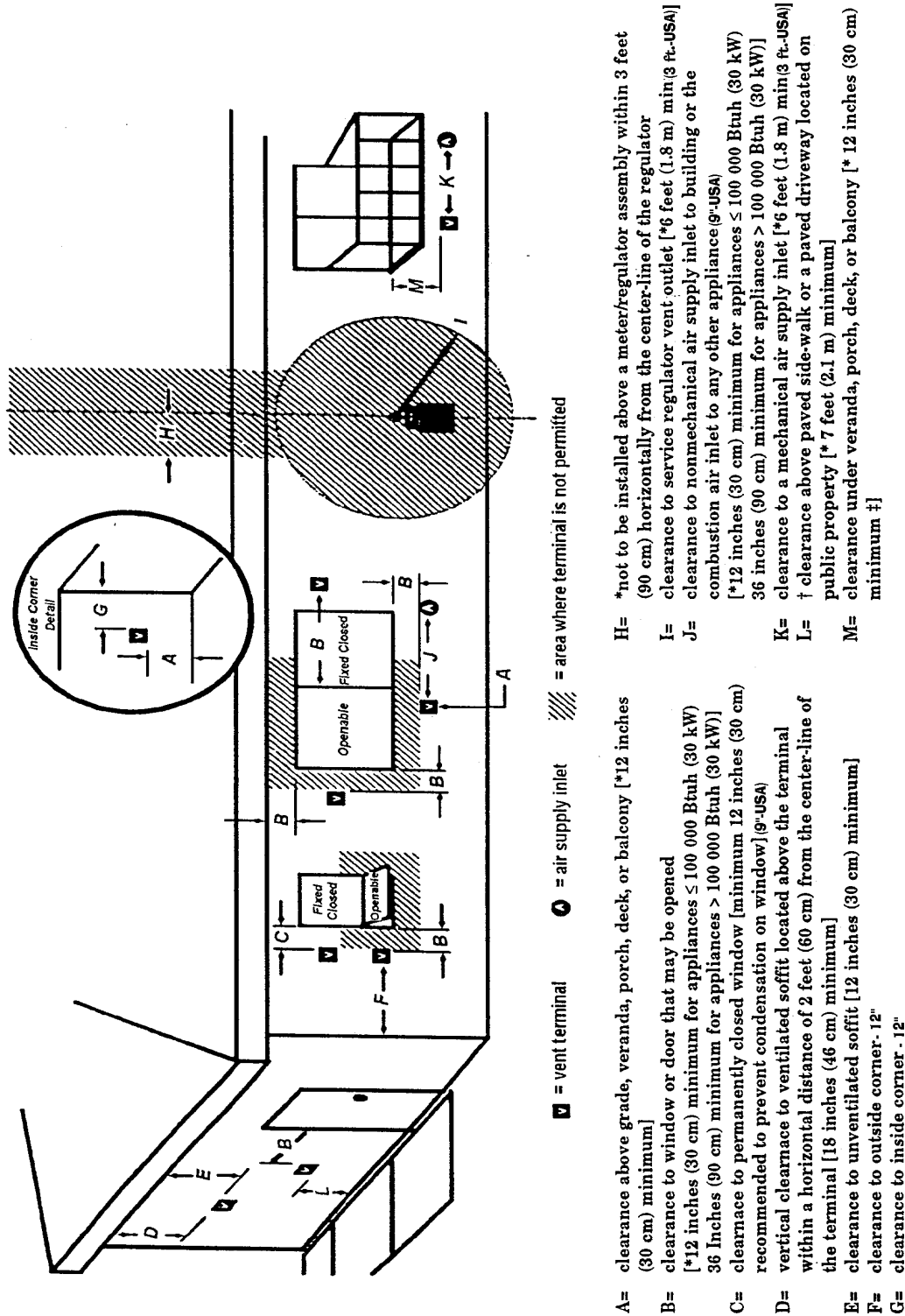

Figure 6

- A= clearance above grade, veranda, porch, deck, or balcony [*12 inches (30 cm) minimum]
 - B= clearance to window or door that may be opened [*12 inches (30 cm) minimum for appliances ≤ 100 000 Btuh (30 kW) 36 Inches (90 cm) minimum for appliances > 100 000 Btuh (30 kW)]
 - C= clearance to permanently closed window [minimum 12 inches (30 cm) recommended to prevent condensation on window] (g-USA)
 - D= vertical clearance to ventilated soffit located above the terminal within a horizontal distance of 2 feet (60 cm) from the center-line of the terminal [18 inches (46 cm) minimum]
 - E= clearance to unventilated soffit [12 inches (30 cm) minimum]
 - F= clearance to outside corner - 12"
 - G= clearance to inside corner - 12"
 - H= *not to be installed above a meter/regulator assembly within 3 feet (90 cm) horizontally from the center-line of the regulator
 - I= clearance to service regulator vent outlet [*6 feet (1.8 m) min(3 ft.-USA)]
 - J= clearance to nonmechanical air supply inlet to building or the combustion air inlet to any other appliance (g-USA) [*12 inches (30 cm) minimum for appliances ≤ 100 000 Btuh (30 kW) 36 inches (90 cm) minimum for appliances > 100 000 Btuh (30 kW)]
 - K= clearance to a mechanical air supply inlet [*6 feet (1.8 m) min(3 ft.-USA)]
 - L= † clearance above paved side-walk or a paved driveway located on public property [* 7 feet (2.1 m) minimum]
 - M= clearance under veranda, porch, deck, or balcony [* 12 inches (30 cm) minimum †]
- = vent terminal ● = air supply inlet ▨ = area where terminal is not permitted
- † a vent shall not terminate directly above a side-walk or paved driveway which is located between two single family dwellings and serves both dwellings*
 - ‡ only permitted if verand, porch, deck, or balcony, is fully open on a minimum of 2 sides beneath the floor*
 - * as specified in CGA B149 Installation Codes Note: local Codes or Regulations may require different clearnaces

VENTING INFORMATION

VENT CONNECTION

Starter collar is installed by HearthStone.

1. The Stowe Direct Vent is approved for installation only with the vent connecting components listed on this page and Simpson Dura-Vent Direct Vent GS, AmeriVent Direct, or Secure Vent systems. Use the following instructions along with the pipe manufacturer's instructions to complete the installation.
2. To attach the Restrictor Plate; see instructions included with it. It will attach from inside the firebox, after removal of the brick patterned baffle. The two screws required are included in the appliance. Be sure you can see the screw head for future adjustments.
 - a. *NOTE:* For minimum venting configurations, discard the restriction plate- see section "Approved Vertical Termination Venting Configurations"
3. Install the rest of the vent system according to the manufacturer's instructions.

Figure 9: Key

1. Restriction Plate	5950-922
2. Gasket 4"	3160-155
3. Inner starter	924H1
4. Gasket 6"	3160-157
5. Outer Starter	924H1

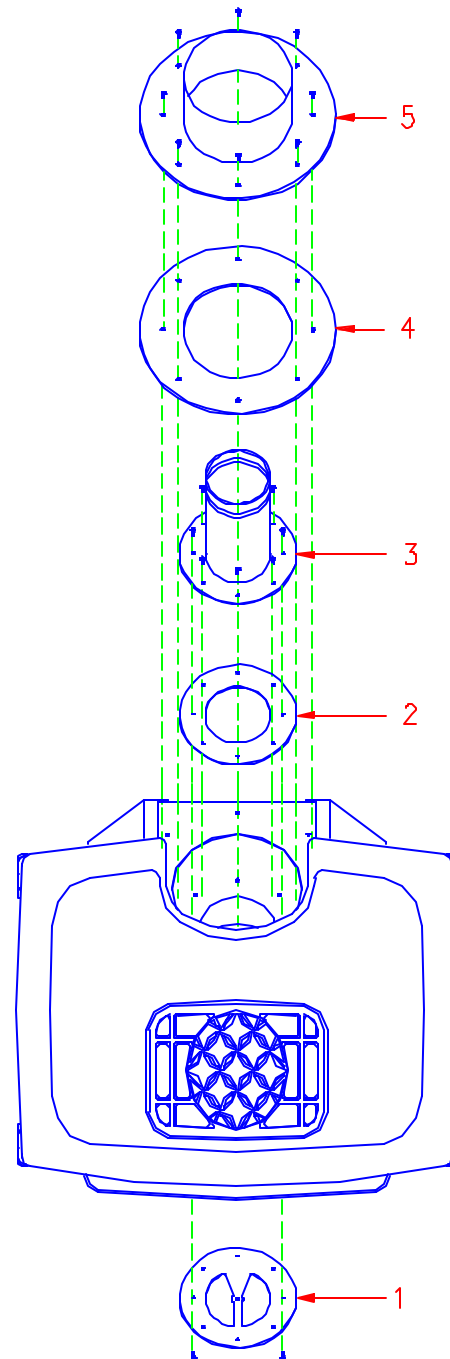

Figure 7: Starter collar and Restriction Plate assembly

RESTRICTION PLATE

The restriction plate is used to control the draft of the heater. Controlling the draft also changes the aesthetics of the flame. The restriction plate has eight settings, one (1) being the lowest and eight (8) being the highest. For a fast moving flame with lots of action, use a low setting. For a slow, lazy flame, a high setting should be used. See Figure 9 for instructions on how to adjust the restriction plate settings.

RESTRICTION PLATE POSITION

A vent restriction plate is available for the appliance to adjust the flow rate of exhaust gases. This insures proper flames for the wide variety of vent configurations, and efficiency. The restriction plate consists of a rotating shutter below the starter section of pipe and an adjustment plate with index holes used to hold the shutter in a fixed position. Depending on the vent configuration, you may be required to adjust the restriction plate position. Refer to page 17-18 for positioning of the restriction plate.

ADJUSTMENT TO RESTRICTION PLATE

Remove the log set before adjusting the restriction plate by following the log set removal instructions on page 24. Make sure the unit is cool before touching any part of the firebox and log set. Remove the exhaust baffle by removing the one screw in the center of the baffle (refer to Figure 9). The baffle will come out once the screw is removed. *Be careful not to drop the baffle on the pan burner.* Once the baffle is set aside, check the restriction plate screw location. There are eight locations that the restriction plate can be positioned. (Refer to Venting Configuration – Figures 10 – 15 for recommended restriction plate positions)

(Refer to Figure 7 for proper adjustment plate index location) ‘A’ in Figure 9 shows the locating screw that determines the position of the plate.

NOTE: These positions are based on lab results and can have some variance.

Remove the screw and position the restriction plate in the desired location. Fasten the screw into the proper hole and tighten. Reinstall the exhaust baffle by setting the back edge of the baffle into the baffle clip attached to the back wall of the firebox. Then push the baffle against the heat exchanger and reinstall the screw. Reinstall the log set and ember strip as described in the log set installation procedure on page 27.

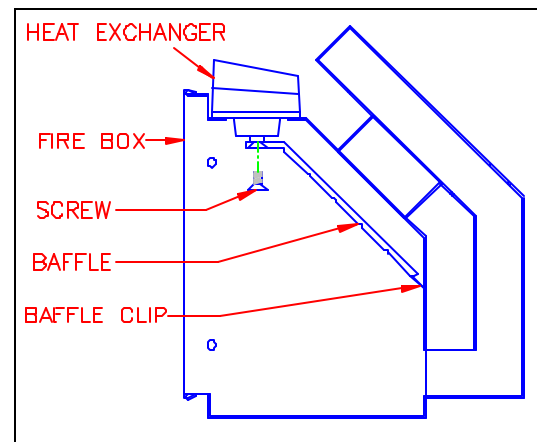

Figure 8: Baffle Removal

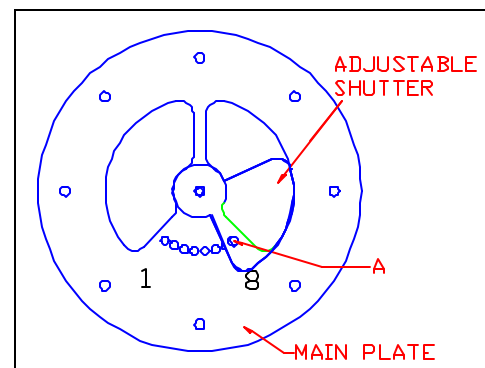

Figure 9: Restriction Plate Adjustments

VENTING COMPONENTS & CONFIGURATION

The Stowe cannot be vented jointly with any other solid fuel or gas appliance. It must be vented directly to the outside of the building using a proper termination as listed in the manual. The only type of venting pipe approved for use with your Stowe Direct-Vent stove is Simpson Dura-Vent's GS, AmeriVent Direct, and Secure Vent Direct-Vent Pipe. The venting configurations are shown in Figures 10 - 15. After determining the venting configuration for your stove, select the vent system that will accommodate your installation.

Caution: Make sure all stove and termination cap clearances have been observed per the Owner's Manual.

Caution: Be sure there is no wiring or plumbing in the chosen location.

Caution: Venting terminals shall not be recessed into a wall or siding.

Note: If further direction is needed for installation, please refer to the venting instructions, which are provided with the venting components.

ACCEPTABLE DIRECT-VENT TERMINATION CAP LOCATIONS

The vent/air intake termination clearances above the high side of an angled roof are as follows:

Roof Pitch	Feet	Meters
Flat to 6/12	1	0.3
7/12 to 9/12	2	0.6
10/12 to 12/12	4	1.2
13/12 to 16/12	6	1.8
17/12 to 21/12	8	2.4

Listed below are Simpson Dura-Vent, AmeriVent Direct, and Secure Vent components acceptable for installation, along with the minimum venting kit available. The venting system must be comprised of the appropriate venting components as specified.

APPROVED VENTING SYSTEM COMPONENTS

*Component Description

90° Elbow
 45° Elbow
 6" Straight
 9" Straight (Simpson only)
 12" Straight
 24" Straight
 36" Straight
 48" Straight
 11"-14 5/8" Adjustable Pipe Length
 Horizontal Vent Cap
 Vertical Vent Cap
 14" Snorkel
 Vinyl Siding Standoff 4 x 6 5/8"
 Round Ceiling Support Wall
 Thimble Covers
 Wall thimble

CHIMNEY LINER SYSTEM

1. Direct-Vent Chimney Liner Termination Kit
2. Chimney Liner Flex
3. Co-Linear Flex Connector
4. Co-Axial to Co-Linear Appliance Connect

*MINIMUM VENT KIT

*HearthStone Stove Starter Collar
 45° Elbow
 90° Elbow
 (2) 9" Straight
 Round Ceiling Support
 Wall Thimble Cover
 Wall Thimble
 Horizontal Vent Cap

*Supplied by HearthStone

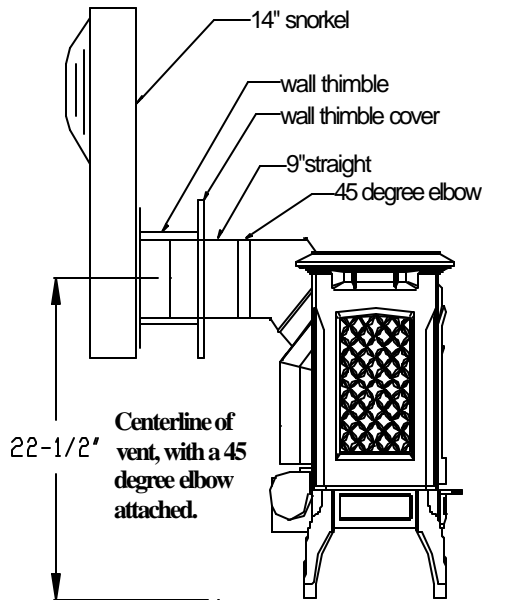

Centerlines shown are approximate. Please dry fit your venting and take a measurement. Pipe dimensions will vary by manufacturer and supplier.

See installation instructions on page 23.

Figure 10: Components For a Typical Snorkel Installation

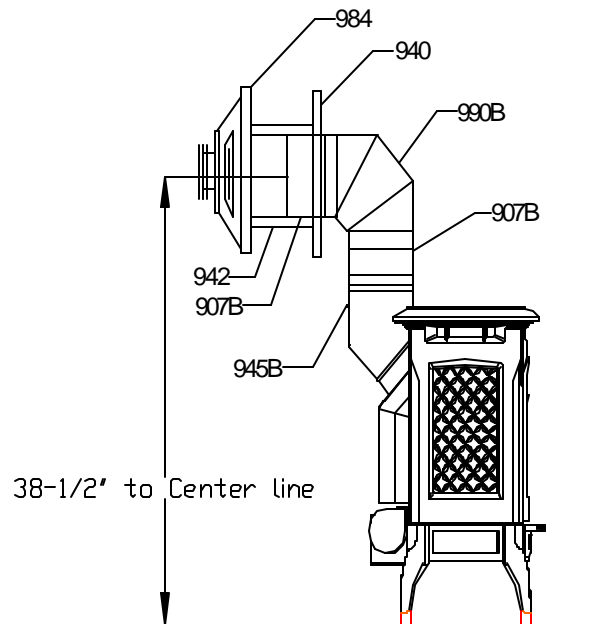

Figure 11: Components for a Typical Minimum Horizontal Venting Installation

APPROVED VERTICAL TERMINATION VENTING CONFIGURATIONS WITH NO ELBOWS OR (2) 45° OFFSETS (FIGURE 12), AND (2) 90° ELBOWS (FIGURE 13)

- 10' minimum system height (with or without offsets)
- 35' maximum system height
- 6' maximum offset (refer to Figure 12)
- 12' maximum offset (refer to Figure 13)
- The termination must fall within the outline shown in Figures 12 & 13. Use the indicated restriction plate position. The restriction Plate part # is 5950-922.

CLEARANCES FROM THE PIPE TO COMBUSTIBLES:

- 1" to vertical runs
- 1" below and to the side of horizontal runs
- 2" from the top of horizontal runs

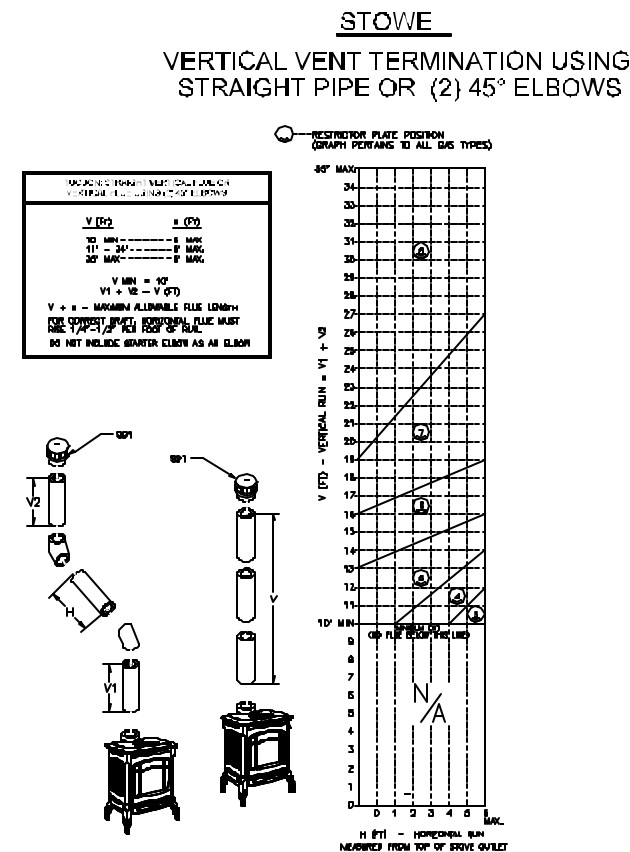

FIGURE 12 VERTICAL TERMINATIONS USING STRAIGHT PIPE

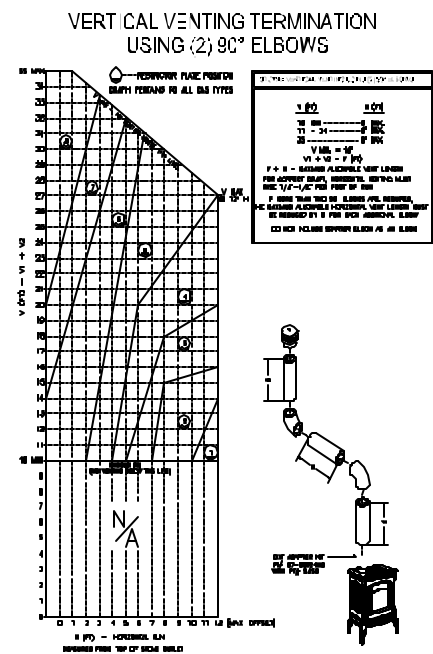

FIGURE 13 VERTICAL TERMINATIONS USING (2) 90° ELBOWS

APPROVED VENTING CONFIGURATION FOR HORIZONTAL TERMINATION, (1) 90° ELBOW

- The termination must fall within the area outlined by the shaded area shown in the illustration below.
- A minimum of a 9” rise is required directly off the heater.
- Use a vinyl siding standoff when installing against vinyl siding.
- Horizontal sections require a 1/4” rise every 12” of horizontal run.

NOTES:

1. The vent must terminate within one of the regions outlined by the shaded area.
2. For each 90° elbow after 2, remove 5’ from horizontal run.
3. **For Canadian installations: remove 4’ from horizontal run.**
4. At minimum vertical rise, maximum horizontal run 14”.
5. Use with snorkel termination 14” maximum horizontal run.

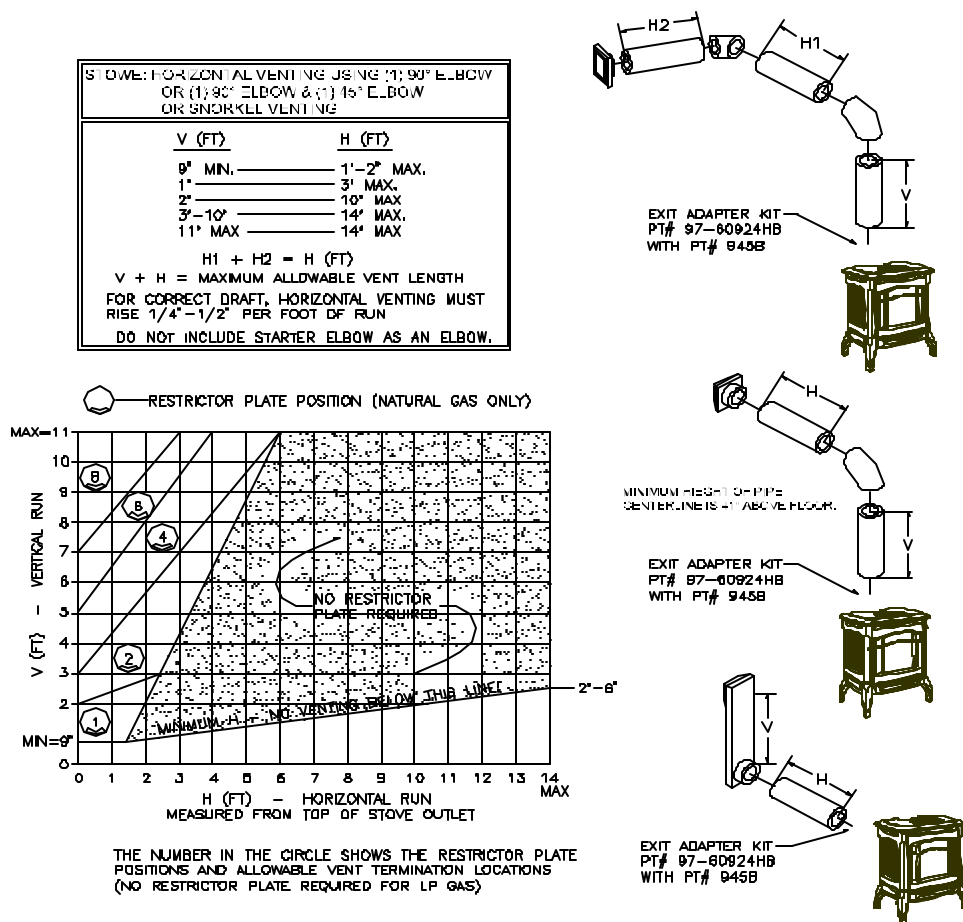

FIGURE 14 HORIZONTAL TERMINATION

APPROVED CONFIGURATION FOR FIREPLACE INSTALLATION

- The termination must fall within the demarcation line shown in the illustration. Use the indicated restriction plate position. Restriction plate # 5950-922.

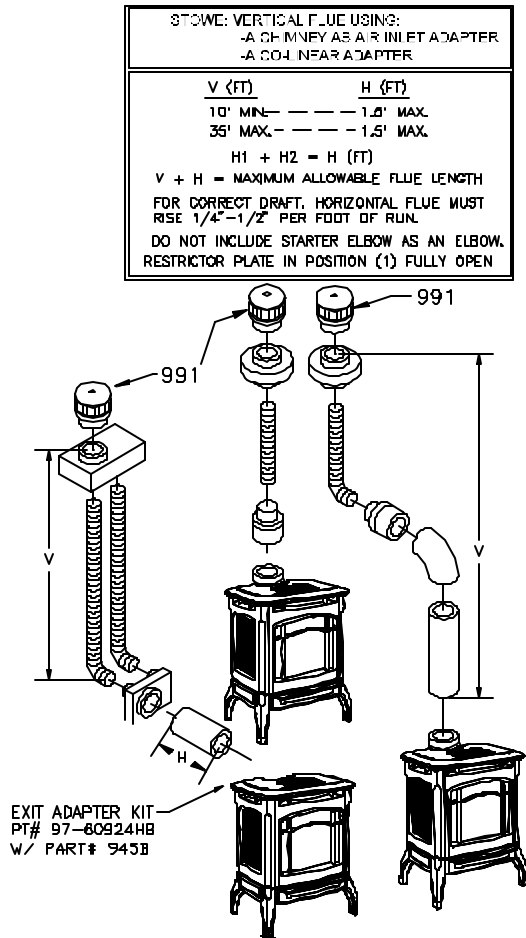

FIGURE 15. CO-LINEAR & CHIMNEY AS AN AIR INLET

INSTALLATION INSTRUCTIONS FOR THE STANDARD HORIZONTAL TERMINATION MINIMUM VENTING KIT (KIT #97-65001)

1. The starter collar is factory installed. Determine if you need a Restriction disc, and install or not.
2. Install the 45° elbow over the outer collar. Place the elbow so that the twist lock end is pointing up.
3. Install one of the 9" pipe sections into the elbow by fully inserting it and turning approximately ¼ turn clockwise, until the 2 sections are fully locked. Install the 90° elbow in similar fashion.
4. Move the stove and pipe assembly back until the 90° elbow is flush to the wall. The 9" vertical pipe should be parallel to the wall. Draw a circle around the pipe. Use the center of this circle as the center point of the 10" x 10" square wall pass through. Cut and frame the wall pass through.
5. Place the interior wall thimble into the 10" x 10" wall pass through. Secure it with 4 screws (not provided). Install the exterior portion of the thimble in similar fashion, overlapping the 2 sections.
- **Caution: For building with vinyl siding, a vinyl siding standoff should be installed between the vent cap and the exterior wall.**
6. Install the horizontal vent termination on the outside of the wall. Make sure both of the retaining

straps extend through interior wall thimble. Before attaching the vent termination to the outside of the house, run a bead of non-hardening mastic around its' outside edges, so as to make a seal between it and the wall. The arrow on the end cap should point up. Secure the cap to the wall with the appropriate screws.

7. Place the thimble cover onto the 90° elbow. Put the 9" pipe into the horizontal vent cap, (the vent pipe must extend into the horizontal vent cap a minimum of 1-1/4"). Move the stove and vent pipe into position, insert the 9" pipe into the 90° elbow and twist to lock it. Secure the straps from the horizontal vent termination to the interior pipe with 2 sheet metal screws, keeping screws close to wall thimble as possible. Bend or cut the excess strapping so that the thimble cover will fit properly. Screw the thimble cover to the wall.

ELECTRICAL CONNECTIONS

NOTE: OPEN VALVE DOOR UNDER THE ASH LIP FOR ELECTRICAL AND GAS CONNECTIONS.

THERMOSTAT

The ON/OFF/T'stat switch or wall mounted thermostat controls the Stowe. We recommend installation of the thermostat for more comfortable performance, however you may still override the thermostat by setting the switch to "ON". The thermostat controls the unit by "calling for heat." The thermostat turns the unit on when the room is cold, and turns the unit off once the room is warmed sufficiently. The thermostat is controlled by a 750 millivolt DC two-wire circuit.

REMOTE CONTROL

There are two different optional remote controls. Both of the remote controls are capable of turning the unit on and off. One of the optional remotes also allows you to control the temperature of the stove, (in the same way the thermostat controls the heater), from anywhere in the vicinity of the unit. If "ON" & "OFF" are the only controls required, Kit #90-56912 can be used. If you would like to control the temperature via the remote control, use Kit #90-56914. Installation instructions are provided with the kits.

THERMOSTAT PLACEMENT

The thermostat should be placed in the same room or living space as the unit. Typically 5' (1.5m) off the floor and away from any influences that may cause the temperature in the vicinity of the thermostat to be unrepresentative of the room temperature in general. Such influences might include strong lighting, a heater vent from the

central heating system, or a nearby drafty window.

Placement of the thermostat on an inside wall rather than an outside wall is preferable. Do not place the thermostat directly behind or too close to the unit, otherwise heat from the unit will immediately satisfy the thermostat and turn the unit off.

THERMOSTAT WIRING

The thermostat should be connected to the Stowe using no more than 40' (12 m) of the provided insulated thermostat wire. The thermostat wire from the Stowe to the thermostat can be surface mounted or routed under the floor, through walls, etc.

Be sure to leave a small coil of additional thermostat wire behind the Stowe so that the unit can be moved out of position for servicing and cleaning.

Connect one of the thermostat wires to the gas control marked **TH** and the other to the yellow wire coming from the on/off T'stat switch. When making these connections, position the thermostat wire so that it extends towards the wall behind the Stowe, then towards the thermostat.

At the thermostat, the wires should be connected to the two connection screws on the back of the thermostat per the instructions received with the thermostat. Take care not to over-tighten the connection screws and not to damage the internal parts of the thermostat.

WIRING INSTRUCTIONS

- CAUTION:** Label all wires prior to disconnection when servicing controls. Wiring errors can cause improper and dangerous operation. Verify proper operation after servicing. *(Attention: Au moment de l'entretien des commandes, étiquetez tous les fils avant le débranchement. Des erreurs de câblage peuvent entraîner un fonctionnement inadéquat et dangereux.)* The proper location of wire connections is shown in Figure 16.

Wiring Diagram - Tucson

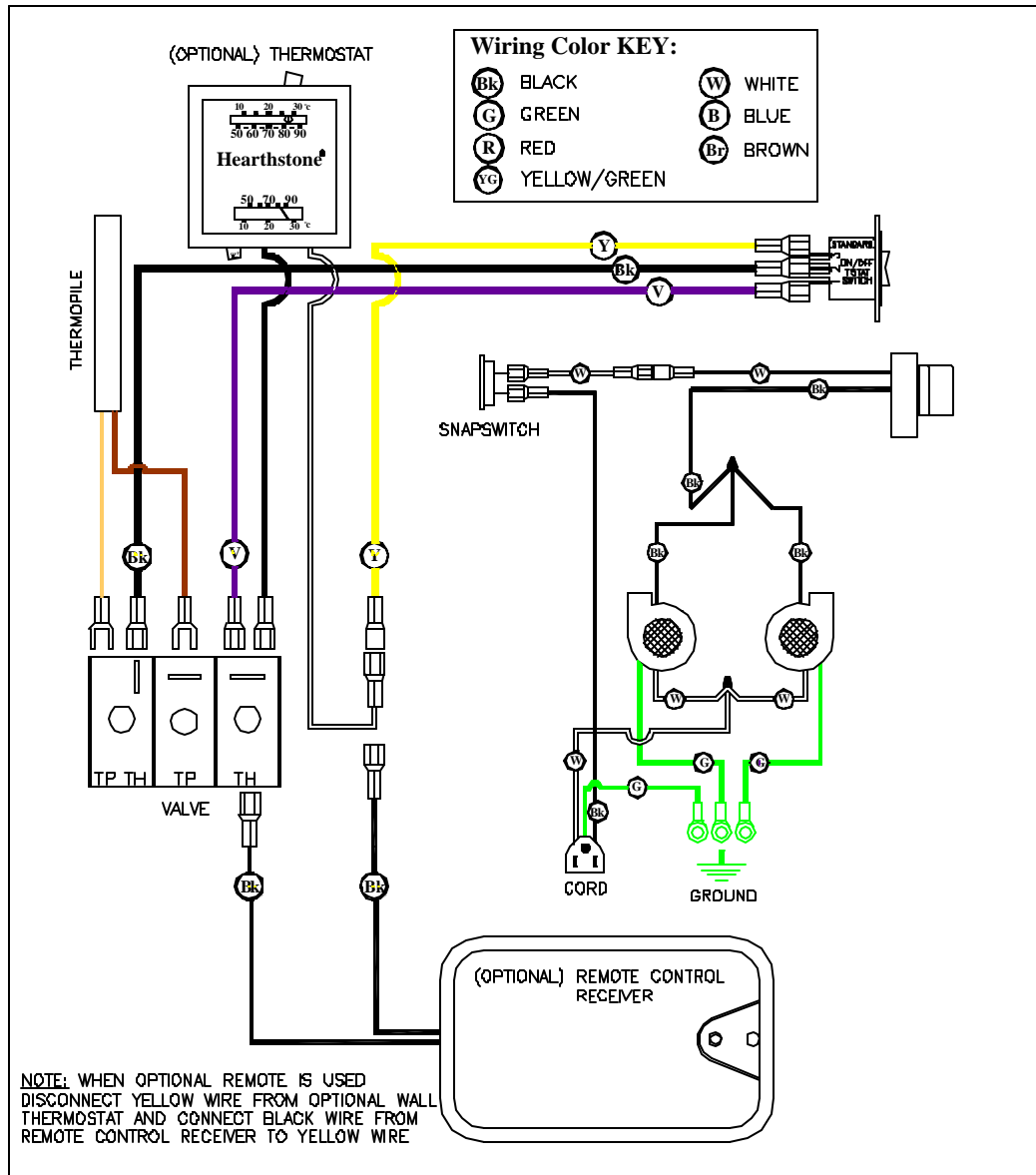

Figure 16: Wiring Diagram

NOTE: If an optional blower is to be installed now or in the future, make sure the gas line is installed as close to the floor as possible.

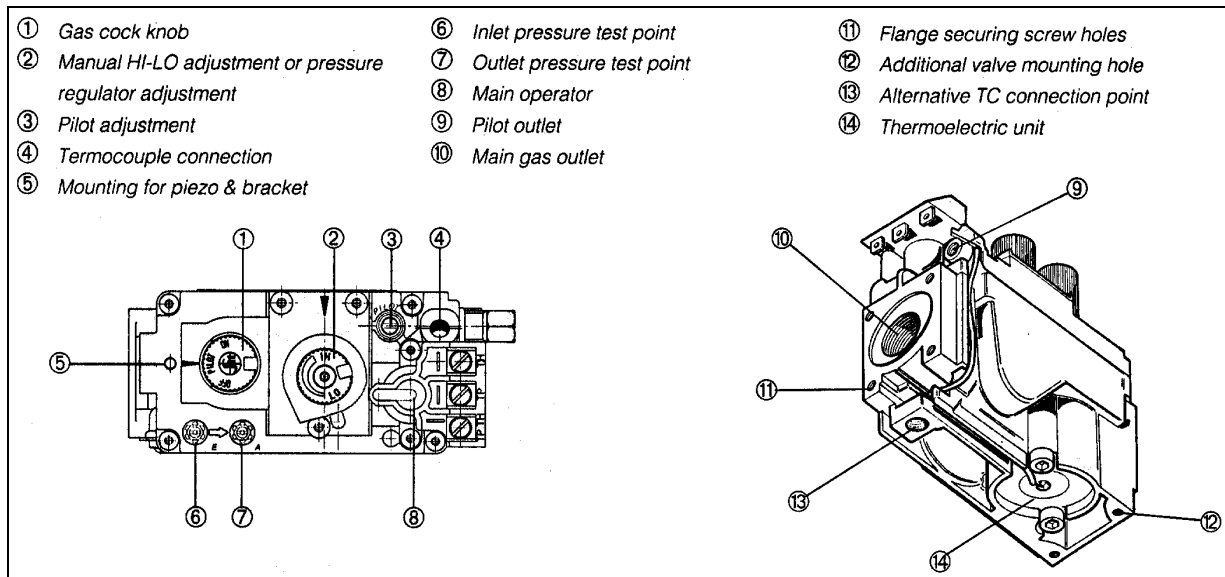
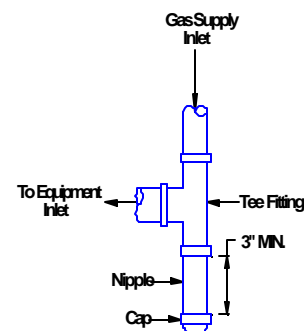

Figure 17: Gas Control Valve

GAS SUPPLY & CONNECTIONS

- **NOTICE:** A qualified technician must connect the heater to the gas supply and leak test the unit before it is approved for use. Consult all codes.
- **WARNING:** The unit must be installed and connected in accordance with local codes, or in the absence of local codes, with the most current edition of the National Fuel Gas Code ANSI Z223.1 (NFPA 54) or CAN/CGA B149 Installation Code.
- NFPA Code, and Hearthstone require the use of a dedicated sediment trap just upstream of the unit. Damage to the valve, or other components due to the lack of a sediment trap are not covered by warranty.



Sediment Trap (Typical)

GAS CONNECTIONS

The gas supply connection is made to the Stowe's gas control valve just inside the left front leg of the unit using a 3/8" male NPT fitting. The supply line should be 1/2" diameter, or appropriately sized to provide a sufficient gas supply to meet the maximum demand of the unit without undue loss of

pressure. We recommend a flexible line to avoid undue mechanical load on the valve and to ease thread alignment, but refer to local codes.

- **CAUTION: Check Gas Type!**

GAS SUPPLY

This appliance and its individual shutoff valve must be disconnected from the gas supply piping system during any pressure testing of that system at test pressures in excess of ½ psig. The Stowe must be isolated from the gas supply piping system by closing its individual manual shutoff valve during any pressure testing of the gas supply piping system at test pressures equal to or greater than ½ psig.

GAS PRESSURE ADJUSTMENT

NOTE: A QUALIFIED TECHNICIAN MUST PERFORM THIS PROCEDURE!

Once connected to the gas supply, the supply line and manifold gas pressures must be tested. The supply line pressure is tested, to insure it meets the minimum gas supply pressure as listed in the Specifications for the type of fuel in use (natural gas or LP), by connecting a manometer to the supply line and adjusting the incoming pressure if necessary to meet the required supply line pressure as listed in specifications. The manifold pressure tap on the gas control valve, refer to *Figure 17* for location.

LOG PLACEMENT

CAUTION: Fragile! Handle log set with care. Always wear gloves and safety goggles while handling the log set.

Only the decorative ceramic log set supplied with the unit should be placed in the firebox. Do not place any other ceramic logs, wood logs, or other materials in the firebox. If the

log set is damaged or broken contact your dealer for replacement. The decorative ceramic log set will last a long time, however, they will break if subjected to rough or improper handling. Exact positioning of the log set is required in order to obtain a pleasing flame pattern and efficient combustion. Incorrect log placement may cause carbon build-up; excess thermal stress on the log set and stove parts, reduced efficiency, and high levels of carbon monoxide. If the log set does not set into the firebox exactly as outlined, contact your dealer for assistance.

INSTALLATION OF THE LOG SET

(Refer to the following images in this section for log set assembly)

1. Pull off the glass frame by prying up the two metal clips on top of the firebox. Once these are pulled up, the frame can be pulled away from the firebox, and off the stove.
2. Remove the packaging material around the log set assembly. Be careful not to damage the log set when unpacking. Observe the 4 mounting “posts”, Right, Rear, Left, and Front.

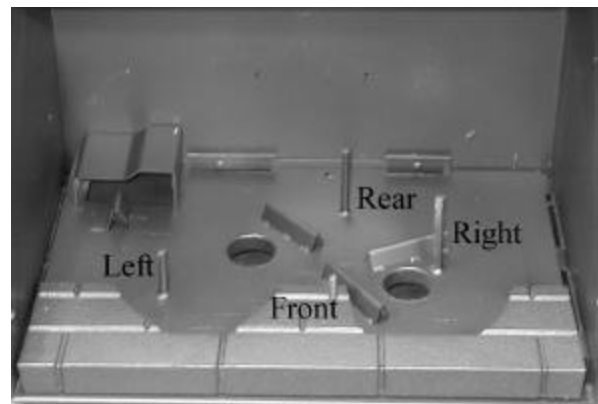

3. Gently slide the Forked Log (1) onto the Right post and the Rear post, with the forked end toward the front right of the firebox.



4. Gently slide the “Cordwood” style log (2) onto the Rear post and the Left post, with the rear portion of the log on top of the Forked Log (1).



5. Gently slide the Straight Log (3) onto the Right post and the Front Post, with the Charred end towards the front.



6. Gently place the Top Log (4) in the indentation on the Cordwood Log (2) and the pilot assembly, being sure to slide the end into the rear corner of the firebox.
7. Spread the Charcoal Embers evenly across the Pan Burner, ***one layer high***. You may, or may not, need to use all of the Charcoal Embers. Keep the remainder to use in the future. Do not block the air opening under cast brick panel in any way.



Locate and open the bag of rock wool. Pull apart small pieces of the wool and sprinkle over the Charcoal Embers randomly. This wool will glow once the unit is running.

8. Replace the glass frame by sliding it down the face of the firebox and pushing the top back. Slide the two clips back down to hold the frame in place.

REMOVAL OF LOG SET

CAUTION: The log set and charcoal embers retain heat and can be very hot! Allow 2 to 3 hours after pilot light is turned off before handling.

To remove the log set, follow the Installation of Log Set instructions in the reverse order.

LIGHTING THE UNIT FOR THE FIRST TIME

- **WARNING:** If you do not follow these instructions exactly, a fire or explosion may result causing property damage, personal injury or loss of life.
- **CAUTION:** Lighting the Stowe for the first time and adjustments to the unit should be performed by qualified service personnel.

SMOKE AND FUMES WARNING

When lit for the first time, the Stowe will emit some smoke and fumes. This is normal “off-gassing” of the paints and oils used in the manufacturing and assembly of the unit. Open windows to vent the room if necessary. The off gassing and fumes will subside after the first 10 to 20 minutes of operation.

BREAK-IN WARNING

The cast iron and cement used in the assembly of the Stowe must be heated up slowly to avoid damaging it. This is accomplished by adhering to the following break-in procedure.

BREAK-IN PROCEDURE

When lit the first time, the Stowe should be burned for no more than 15-30 minutes, and then allowed to cool for 1 hour. This gentle warming and cooling of the unit will allow the cast iron and cement to cure properly. Once this break-in procedure has been completed, the Stowe can be burned at will with no time restrictions on the length of burn.

ODORS AND IMPURITIES

A heater of this type may produce odors during heater operation due to impurities that may exist in the immediate area. Sources of impurities can be cleaning solvents, paint solvents, cigarettes, candles, smoke, pet hair, dust, adhesives, new carpet, and/or textiles. Such odors will dissipate. However, opening a window or otherwise providing additional ventilation to the area can alleviate the condition. If any odor persists, contact your dealer or an authorized service technician.

PILOT LIGHT WARNING

The Stowe has a piezoelectric spark igniter (the red push button located next to the gas control valve behind the valve access door), which ignites the pilot light by means of a spark at the pilot light assembly. Do not attempt to light the unit with a match or by any means other than the piezoelectric spark.

PREPARE FOR LIGHTING

Prepare for the lighting procedure by adjusting the thermostat (if equipped) to its lowest setting or OFF position. If the gas control knob is not in the OFF position, turn the knob fully clockwise to OFF. Locate the variable output control knob and turn it fully clockwise to the highest setting.

Prior to lighting the unit for the first time, wait 5 minutes to allow any residual gas within the unit to dissipate. Smell all around the appliance area for gas. Be sure to smell next to the floor because some gases are heavier than air and will settle on the floor. If you do not smell gas after this five-minute period, proceed with the lighting procedure. If you do smell gas, **DO NOT** proceed with the lighting procedure. Instead, **immediately refer to the What To Do If You Smell Gas Warning, on the cover of this manual.**

WARNING: The valve control has an interlock device. After shutting off all gas flow, the pilot burner cannot be relit until the thermocouple has cooled, allowing the electromagnet to be released (approx. 60 seconds). The gas control knob is designed to operate by hand. Do not use any tools during this operation. Damaged knobs may result in serious injury.

And I

INITIAL ADJUSTMENTS

Once the Stowe has been set in place, connected and assembled as described in the Clearances To Combustibles, Venting Components & Configurations, Electrical Connections, And Gas Supply and Connections sections of this manual, the unit is almost ready to be lit for the first time. The manufacturer tests each unit prior to shipment, so ignition should take place without failure. However, a number of small adjustments may be necessary to compensate for variations in gas pressure, altitude, and other factors particular to each installation.

VARIABLE OUTPUT CONTROL

The gas control valve is equipped with a variable output control. This control varies the rate of heat produced by the unit by varying the gas pressure to the pan burner. A combination of heat output and the thermostat setting affect the length of the burn cycle. If your stove turns on and off too often, try, first, reducing the burn cycle by turning the HI/LOW knob, on the control valve, to a lower setting. Using the variable output control, the heat output of the unit can be reduced for mild fall and spring months, or maximized for the colder winter months. This adjustment can be made, by the homeowner, as necessary by turning the variable output control knob to “HI”, “LO” or any setting in between.

AIR SHUTTER

The air shutter is used to regulate the air-to-gas combustion mixture, which in turn influences the size and color of the flames. The air shutter is positioned in the general location needed for the type of gas being used, however, if the unit is not burning as well as it should, then the air shutter may need adjusting. The air shutter may need adjustment once the unit has been installed

to compensate for variations in supply line pressure, restriction plate position, altitude, gas type conversions, and other variables.

To determine if the air shutter needs adjustment, it is necessary to view the flame pattern with the variable output control knob at its highest setting. Allow the unit to operate for at least 10 minutes to allow the entire unit to reach temperature, and for the flame pattern to stabilize. Generally, the more air (open shutter) in the mixture, the bluer the flame. Less air (closed shutter) results in a more yellow flame, but too little air will result in incomplete combustion, low efficiency and a dirty burn. There are two simple guidelines to aid in determining the correct flame pattern:

1. If the flame at the base of the logs is completely blue, the air shutter may be open too far;
2. If the flame is dirty or licks the top of the stove, the air shutter may be closed too far.

Some conditions cannot be corrected through air shutter adjustment; an adjustment must be made to the gas supply pressure or by changing the restriction plate location. Qualified service personnel must perform supply line/manifold gas line pressure adjustments and restrictor plate adjustments. Do not attempt to complete any part of the installation or adjustment of this unit unless technically qualified to do so.

LIGHTING INSTRUCTIONS

NOTE: The gas control knobs and the piezo igniter are located behind the control valve access door, under the front of the unit.

1. STOP! Read the What To Do If You Smell Gas! Warning (on the cover of this manual).
2. Set the on/off/T'stat switch or thermostat to the "OFF" position.

3. Unplug the fan accessory, if so equipped.
4. Push in and turn gas control knob clockwise to "OFF". (*If not previously lit, the knob should be in this position.*)
5. Wait (5) five minutes to clear out any gas. If you then smell gas, STOP! *Smell all around the appliance area for gas. Be sure to smell next to the floor because some gases are heavier than air and will settle on the floor. **If you smell gas immediately follow the What To Do If You Smell Gas! warning on the cover of this Manual.*** If you do not smell gas, proceed to the next step.
6. Turn gas control knob counter-clockwise to "PILOT".
7. Push in control knob all the way and hold in. Immediately light the pilot with the gas lighter (push in and "click" the piezoelectric spark igniter button several times until lit). Continue to hold the control knob in for about 20 seconds after the pilot is lit. Release the knob and it will pop back out. Pilot should remain lit. If the pilot goes out, repeat the operation.
 - If knob does not pop out when released, stop, shut off the gas supply to the heater and immediately call a qualified service technician or gas supplier.
 - If the pilot will not stay lit after several tries, turn the gas control knob "OFF" and call a qualified service technician or gas supplier.
8. After the pilot lights, turn gas control knob counter-clockwise to "ON".
9. If the ON/OFF/T'stat switch is set to "ON", the stove should now be lit. If the thermostat (or remote) has been installed, set the ON/OFF/ T'stat switch to "T'stat" and turn the thermostat (or

remote) to “ON”. Then set the desired temperature.

10. Shut the gas control valve access door.
11. Plug in the fan accessory, if so equipped.
12. If T’stat was selected, set thermostat to “ON” and set desired temperature setting. Normally, if T’stat position was selected, the main burner is cycled on and off by the thermostat or the “on/off” switch located on the bottom of the thermostat body.

NOTE: When pressing/clicking the piezoelectric spark ignition button to light the pilot, watch through the glass (front) of the unit. Click the igniter button until a flame is visible at the pilot. Once the pilot is lit, continue to press on the gas control knob for another 20 seconds, then release. Ascertain that the pilot is still lit by looking through the front door. If lit, then turn the gas control knob fully counter-clockwise to the “ON” position. If the pilot fails to light, or if it went out due to a premature release of the gas control knob while depressed in the “PILOT” position, wait 60 seconds for the Interlock to release. Then repeat the lighting process as described in this section of the manual.

Once the pilot has been lit, the gas control knob has been turned to the “ON” position, and the ON/OFF/T’stat switch has been turned to “ON”, the main burner should light immediately. If you would like to use the thermostat and it has been installed, switch the ON/OFF/T’stat switch to thermostat. Turn the thermostat to "ON" and set it to a higher position so that it "calls" for heat in order to light the main burner (i.e. turns the unit on). Note that the thermostat controls the on/off cycling of the main burner, but the pilot remains lit regardless of the thermostat setting. The only way to turn the pilot off is to turn the gas control knob fully clockwise to the “OFF” position.

TO TURN OFF GAS TO APPLIANCE

1. Set the thermostat to the “OFF” position or turn the ON/OFF/T-STAT switch to the “OFF” position.
2. If shutting the unit off for the non-heating season, turn the gas control knob fully clockwise to the “OFF” position. Do not force the knob to turn.

AIR SHUTTER ADJUSTMENTS

The air shutter, located at the lower rear center of the stove, is adjustable while the stove is burning by loosening the set nut on the adjusting bolt located on the lower rear left of the stove. This nut is hot and should not be touched. Use only metal tools for this adjustment. Loosen the set nut and turn the bolt to adjust the flame pattern. Turn the bolt clockwise to open the air shutter, and counterclockwise to close the shutter. When the flame pattern is correct, tighten the set nut without letting the bolt turn. The air shutter is factory set and only a qualified gas technician should make adjustments.

Note: Very little movement is needed to substantially change the burn and flame patterns. Some conditions cannot be corrected through air shutter adjustment; an adjustment must be made to the gas supply pressure. Supply line/manifold gas line pressure adjustments must be performed by qualified service personnel. Do not attempt to complete any part of the installation or adjustment of this unit unless technically qualified to do so.

PILOT ADJUSTMENT

The pilot light is preset by the manufacturer and should not need adjustment. The pilot light flame should be large enough to engulf the thermopile and thermocouple located next to the pilot, but not so large as to create excessive noise or consume excessive gas. (Refer to figure 18) However, it can be adjusted by means of the pilot light adjustment screw located on the gas control valve. Open the valve door to access the pilot adjustment screw. Note that the pilot flame must engulf the thermopile so that the thermopile can generate sufficient milli-voltage (325 to 500-mv) to power the gas control valve. The flame on the pilot should look like Figure 18. Controlling the Stove by the wall-mounted thermostat may become erratic, nonexistent, or the unit may go out, if the pilot flame is too small or misdirected away from the thermopile.

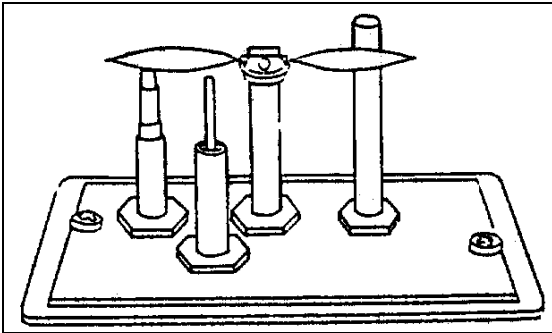

Figure 18 Pilot Flame Pattern

- **WARNING**

The control has an interlock device. If the stove has been lit, it will not relight immediately. After shutting off all gas flow, the pilot burner cannot be relit until the thermocouple has cooled, allowing the electromagnet to be released (*Approx. 60 sec.*). The gas control knob is designed to operate by hand. Do not use any tools during this operation.

BURNER FLAME APPEARANCE

Once the unit is lit, observe the flame

pattern and adjust as necessary. Also, a periodic visual check of the burner flame should be performed. The burner flames can be adjusted by means of the air shutter. To determine if the burner flame needs adjustment, it is necessary to view the flame pattern with the variable output control knob at its highest setting (turn fully clockwise). Allow the unit to operate for 10 minutes enabling the entire unit to reach temperature and for the flame pattern to stabilize. The flame pattern should be similar to the one shown in Figure 19. There are several guidelines to aid in determining if the flame pattern is correct:

1. The flame should not be dirty, smoky, sooty, or lick the top of the stove.
2. The flame should not rise off the pan burner; this is called “lifting”.
3. Flames should not impinge heavily on the log set. They should “fit” through the pre-formed spaces designed in the log set.

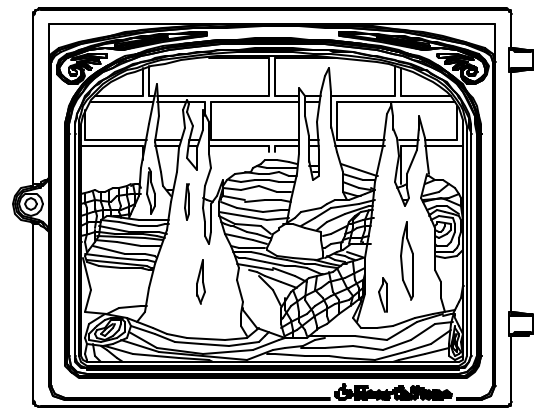

Figure 19: Typical Burner Flame Appearance

ROUTINE MAINTENANCE AND CARE

The Stowe requires minimal routine maintenance and care. The unit should always be cool and off when being cleaned, or serviced.

- **WARNING: Do not substitute materials.** For replacement parts, or for information about parts or service, contact your local HearthStone dealer.

CLEANING

- **WARNING: Do not clean the unit when hot.**

The unit should receive regular cleaning on, under, and around the stove to prevent the buildup of dust and lint. The exterior surfaces of the unit can be cleaned using soap, water, and a soft cloth. **Do not** use abrasive or chemical cleaners and take care not to scratch the glass or enamel finish (if so equipped) when cleaning the unit. The use of chemical wax based cleaners or polishes are not recommended due to the potential for discoloration of the castings or enamel when the residue of the cleaners or polishes are exposed to heat. Excessive buildup of dust, spider webs, or room air contamination may cause odors when the stove is hot.

FIREBOX, PILOT, & BURNER ASSEMBLY

The firebox requires periodic cleaning to prevent the accumulation of dust, lint, and other debris. To clean the firebox, set the thermostat to the “OFF” position, and turn off the gas at the gas control valve. When the unit is cool, unfasten the front door and carefully remove the decorative ceramic log set, taking care not to damage the logs or chip the enamel cast iron. Remove all glowing ember material. Clean the firebox pan burner, and carefully vacuum the entire

surface of the log set. Thoroughly vacuum the ports (holes) along the top of the pan burner, and the pilot assembly.

With the decorative ceramic logs out of the firebox, fasten the door shut and briefly light the unit according to the lighting instructions described on page 28. Check to insure a proper flame is burning from each burner port. The pilot flame should be large enough to engulf the thermopile and thermocouple as shown in Figure 18.

NOTE: Do not operate the unit for more than 1-2 minutes without the log set in place. Turn the unit off by setting the thermostat to “OFF”, and turning the gas control valve off. Allow the unit to cool.

Check and clean any burner ports that are not burning, or not burning properly. Clean burner ports using a soft brush or vacuum cleaner. If the pilot flame height needs adjustment, it should be adjusted by qualified service personnel as described on page 29.

Complete the cleaning procedure by carefully placing the log set within the firebox as described on page 24. Close and fasten the front door. Turn on the gas, light the unit and check for proper operation. Flame patterns should look similar to the flames in Figure 19. Regularly check to insure the area around the Stowe is kept free from combustible materials, gasoline, and other flammable vapors and liquids. Check that the flow of combustion and ventilation air is not obstructed. **Once a year, the unit, and venting system should be inspected by qualified service personnel to insure that they are clean, free of obstruction, safe, and in good working order. If service or maintenance is required, qualified service personnel should perform it.**

REPLACE THE FRONT DOOR GASKET AS NEEDED

Your Stowe uses a 3/8" rope-type fiberglass gasket to make a tight seal between the doorframe and the firebox. In time, the gasket can become brittle and compressed and should be replaced. New gasket material is available from your Authorized HearthStone Dealer. Protect your hands with work gloves, and wash up later.

1. Allow the Stowe to cool completely. Remove the existing gasket by grasping one end and pulling firmly.
2. Use a wire brush or the tip of a screwdriver to clean the channel of remaining gasket.
3. Determine the correct length of the appropriate-sized gasket by laying it out in the channel. Allow an extra 1 to 2" (25-50mm), and mark the spot to be cut.
4. Cut the gasket at the marked spot with a utility knife. Twist the ends slightly to prevent the gasket from unraveling.
5. Apply water glass adhesive to the gasket channel.

6. Starting at one end, press the gasket into the channel. Insure a good joint where the gasket ends meet before trimming any excess. Do not overlap the gasket ends or leave ends with ragged edges.
7. Firmly and evenly, press the gasket to seat it in its channel.

GLASS CLEANING

As fuel gas may contain some impurities; it will be necessary to clean the inside of the glass occasionally. Do not use abrasive cleaners. Scratching the glass will weaken the integrity of the glass. **Do not clean the glass when hot!** Allow the glass to cool and apply a mild window cleaning fluid. Special gas appliance window cleaner is available from your local HearthStone dealer.

- **WARNING:** Do not operate this appliance with the glass panel removed, cracked, or broken. Do not subject the door to abuse, such as striking or slamming shut. Replacement of the glass panel should be done by a licensed or qualified service person.

NOTE: If the vent-air system is disassembled for any reason, re-install per the instructions provided in the venting section of this manual.

PARTS LISTS

Part #	Description	Part #	Description
2310-130	BOTTOM	3160-155	GASKET 4"
2310-220	BRICK PANEL, FRONT	3160-157	GASKET 6"
2310-850	HT EXC. BASE	3160-300	PRIMARY AIR CONTROL GASKET
2310-860	HT EXC.	3170-100	ROCK WOOL (0.1 OZ)
2710-116	BOTTOM CAST	7000-015	THERMOSTAT WIRE 40'
2710-220	ASH LIP	7000-200	3-WAY ON/OFF SWITCH
2710-321	SIDE, RIGHT	7000-301	THERMOSTAT BLOWER SWITCH
2710-326	SIDE, LEFT	7200-340	BURNER ORIFICE (NG) #40
2710-480	EXHAUST BAFFLE	7200-353	BURNER ORIFICE (LP) #53
2710-511	FRONT DOOR	7200-506	THERMOSTAT
2710-560	GLASS RET. FRAME	7210-090	THERMOPILE
2710-581	FRONT GRILL	7210-103	PUSH BUTTON PIEZO IGNITER
2710-655	DOOR HANDLE	7211-009	PILOT TUBE
2710-810	TOP GRILL	7211-023	ORIFICE MOUNT
5300-118	BLAST LIMITER	7211-163	.62 PILOT ORIFICE
5301-030	PRIMARY AIR CONTROL	7211-222	BURNER ASSEMBLY
5321-011	FIREBOX	7211-223	PAN BURNER
5710-121	VALVE BRACKET	7211-310	GAS VALVE SIT
5710-128	VALVE DOOR	7211-370	PILOT BURNER ASSEMBLY
5710-170	DOOR HINGE BRACKET	7211-390	3 WAY PILOT HOOD AND CLIP
5710-180	DOOR LATCH BRACKET	7211-430	PIEZO CERAMIC AND WIRE
5710-512	FIREBOX/AIR PLENUM	7211-470	THERMOCOUPLE
5710-594	EXHAUST BAFFLE CLIP	7211-518	BOTTOM LEFT LOG
5710-596	BACK SHROUD	7211-519	BOTTOM RIGHT LOG
5710-598	BACK SHROUD EXTENSION	7211-520	TOP LEFT LOG
5950-922	RESTRICTION PLATE	7211-521	TOP RIGHT LOG
3030-027	GLASS 13-1/4" X 1/8" X 5MM	7211-517	EMBERS (4 OZ.)(2 REQUIRED)
3110-057	3/8" LOW DENSITY DOOR ROPE		
3160-075	5/8" X 1/4" ROPE GASKET	93-56200	NG CONVERSION KIT
3160-080	3/4" TAPE (GLASS)(FT)	93-56201	LP CONVERSION KIT
3160-150	GASKET FIREBOX/AIR HEAT EXCHANGER	97-57010	BLOWER KIT
3160-152	PILOT GASKET	97-65020	VENT RESTRICTOR

› **WARNING:**

Do Not Substitute Materials. For replacement parts, or for information about parts or service, contact your authorized HearthStone retailer. For the name of the authorized retailer nearest to you, visit our website www.hearthstonestoves.com, call (802) 888-5232, or write:

HearthStone Quality Home Heating Products, Inc.
317 Stafford Ave.
Morrisville, Vermont 05661-8695
E-Mail: inquiry@hearthstonestoves.com

TROUBLESHOOTING

Symptom	Possible Cause	Corrective Action
1. Pilot will not light.	<p>A. Insufficient gas pressure, air in the pilot line, or dirty or kinked gas line.</p> <p>B. Pilot orifice plugged.</p> <p>C. Defective or misaligned electrode at pilot.</p> <p>D. Defective igniter.</p> <p>E. After sitting for "off" season (summer), pilot assembly may be dirty.</p>	<p>A. Using the piezo sparker, try to light the pilot. If it will not light, check the inlet gas pressure.</p> <p>B. Clean or replace the pilot assembly.</p> <p>C. If a match lights a pilot, check the electrode gap and location. Should be a 1/8" gap in the flame area.</p> <p>D. Check for a good connection between igniter and electrode. Check wire insulation. If properly connected and no spark, replace igniter.</p> <p>E. Clean or replace the pilot assembly.</p>
2. Pilot will not stay lit after carefully following lighting instructions.	<p>A. Low or too high gas pressure</p> <p>B. Faulty connections.</p> <p>C. Defective thermocouple.</p> <p>D. Pilot dirty or plugged.</p>	<p>A. Check for proper inlet pressure for the gas being used.</p> <p>B. Measure voltage between valve body and solder connection on the rear of the valve (where the blue wire connects). It should be no less than 7 mV.</p> <p>C1. Ensure that the thermocouple connection at the gas valve is tight.</p> <p>C2. Check thermocouple output using millivolt meter. Disconnect from valve and read voltage across wire ends. If the reading is less than 15 mV, replace the pilot assembly.</p> <p>C3. If burning NG, check pilot flame to see that it is impinging on the top of the thermocouple. Clean or replace pilot for maximum flame impingement.</p> <p>D. Clean or replace the pilot assembly.</p>

TROUBLESHOOTING

Symptom	Possible Cause	Corrective Action
3. Pilot burning, no gas to main burner, valve knob in the "ON" position, thermostat and/or on/off/t'stat switch in the "ON" position.	<p>A. Thermostat switch or wires defective.</p> <p>B. Thermopile may not be generating sufficient voltage.</p> <p>C. Plugged burner orifice.</p>	<p>A. Check thermostat/wiring for proper connections. Place jumper wire across terminals at thermostat. If burner comes on, replace defective thermostat. If not OK, place jumper across thermostat wires at gas valve. If burner comes on, tighten connections, or replace faulty wires.</p> <p>B. Check thermopile output, using a milli-volt meter. Take the readings across generator terminals of the gas valve. (TPTH and TP). Milli-volt reading should be greater than 325 mV. If not, replace the pilot assembly. If the meter reading is OK, but the burner does not come on, replace the gas valve.</p> <p>C. Remove and check burner orifice, clean or replace. Note: do not use any metal cleaning device, as this may damage the orifice.</p>
4. Pilot and burner come on, but go out after some warm-up.	<p>A. Inconsistent, or insufficient flame on thermopile.</p> <p>B. Insufficient gas pressure.</p> <p>C. Excessive draft.</p>	<p>A. Adjust pilot flame size and assure that the flame is aimed directly at the thermopile.</p> <p>B. Check line pressure to ensure that the correct inlet pressure is present for the type of gas being used. If propane pressure is inconsistent, check for water condensation at the regulator.</p> <p>C. Check Restriction settings per this manual.</p>
5. Frequent pilot outage problem.	<p>A. Pilot flame may be too low or blowing, (high), causing the pilot safety to drop out.</p> <p>B. Excessive draft</p>	<p>A. Clean and/or adjust the pilot flame for maximum impingement on the thermopile and thermocouple.</p> <p>B. Check Restriction settings per this manual.</p>
6. Glass fogs	A. A normal result of gas combustion.	A. After the heater has warmed up, the glass should clear.
7. Blue Flames	A. A normal result during the first 20 minutes.	<p>A. Flames should begin to turn more yellowish after 20 minutes of burning.</p> <p>B. If the blue color stays; adjust the air shutter for a proper burn.</p>

TROUBLESHOOTING

Symptom	Possible Cause	Corrective Action
8. Floating flames, lazy ill-defined, quiet flames, which roll around, sometimes completely off of the port, sometimes with overly, yellow tips. Possible sooting. Usually accompanied by the odor of aldehydes.	<p>A. Potentially dangerous incomplete combustion due to incorrect air to fuel ratio (lack of combustion air or excessive fuel delivery i.e. excessive gas pressure, overrating of appliance).</p> <p>B. Incorrect air intake/exhaust flow system. Causes may be:</p> <p>B1. Blocked burner. B2. Blocked primary air B3. Blocked secondary air inlets</p>	<p>A. Check the appliance input rate and reduce if necessary. The air intake/exhaust flow system may be too restrictive or blocked (the rate at which the exhaust leaves [draft] determines the rate at which the combustion air is delivered). Poor draft results in insufficient air delivery or a restricted exhaust. Correct air intake/exhaust flow system.</p> <p>B1. Clear ports. B2. Clear obstructions. B3. Clear obstructions.</p> <p>C. If gas pressures are correct and the flames stay the same, adjust the air shutter for a proper burn.</p>
9. Burner flashback. Air-gas mixture ignites inside the burner near the orifice, usually creating a roaring noise like a blowtorch. The problem is an imbalance of gas flow velocity and burning speed pattern.	<p>A. Excessive primary air.</p> <p>B. Burner input underrated.</p> <p>C. Valve leak if flashback occurs with burner valve in off position.</p> <p>D. Improper gas pipe size.</p>	<p>A. Adjust the air shutter for a proper burn.</p> <p>B. Check input rate. Check input pressure using a manometer. Confirm correct gas pressure at house meter or tank (call gas company). Confirm burner orifice size.</p> <p>C. Replace valve. If above corrections do not eliminate flashback, replace burner.</p> <p>D. Correct plumbing.</p>
10. Delayed ignition (makes a sudden "whoosh" noise as the burner lights). This is a buildup of gas prior to ignition. This is more prevalent with propane (LP) fuel.	<p>A. Incorrect air-to-fuel ratio.</p> <p>A1. Primary air incorrect. A2. Burner ports plugged.</p> <p>B. Improper log placement.</p>	<p>A1. Adjust the air shutter for a proper burn.</p> <p>A2. Open ports to allow for proper travel of flames.</p> <p>B. Reposition logs to eliminate interference with flame travel.</p>

RATING LABEL

MODEL # 8321-
 SERIAL # 5001



MODEL NAME: STOWE DIRECT VENT GAS FIREPLACE HEATER
 LISTED: VENTED GAS FIREPLACE HEATER
 TESTED TO: ANSI Z21.88-2002 CSA 2.33-M02, CAN/CGA-2.17-M91

CERTIFIED FOR CANADA/HOMOLOGUE POUR LE CANADA
 ALSO FOR MOBILE HOME INSTALLATION

DO NOT OPERATE WITH GLASS REMOVED OR BROKEN.

FUEL TYPE:	■ NG	■ LP
INPUT RATING (Btu/hr) 0-2000 ft	26,000	26,000
INPUT RATING (Btu/hr) 2000-4500 ft	25,500	25,500
ORIFICE SIZE (DMS) 0-2000 ft	40	53
ORIFICE SIZE (DMS) 2000-4500 ft	41	54
MANIFOLD PRESSURE - LO SETTING (in. W.c./kpa)	1.2/0.3	3.3/0.8
MANIFOLD PRESSURE - HI SETTING (in. W.c./kpa)	3.5/0.87	10.0/2.48
INLET PRESSURE (in.w.c./kpa)	5.0/1.24	11.0/2.88
MINIMUM INPUT RATING (btu/hr)	15,600	15,600
MAXIMUM OUTPUT (btu/hr) 0-2000 ft	18,100	18,100

This appliance must be installed in accordance with the local codes, if any, if not: follow the National Fuel Gas Code, ANSI Z223.1 or Canadian Installation Codes, CAN/CGA B149. (Installer l'appareil selon les codes ou régle-
 ments locaux, ou, en l'absence de tels régle-
 ments, selon les Codes d'installation CAN/CGA-B149.)

WARNING: Improper installation, adjustment, alteration, service or maintenance can cause injury or property damage. Refer to the owner's information manual provided with this appliance. For assistance or additional information consult a qualified installer, service agency or the gas supplier. (L'AVERTISSEMENT: L'installation inconvenante, ajustement, modification, service ou entretien peut causer le dommages de propriété ou blessure. Référez au manuel d'information de propriétaire fourni cet appareil. Pour l'assistance ou information supplémentaire consultez un qualifiée installateur, agence de service ou le fournisseur de gaz.)

MINIMUM CLEARANCES TO COMBUSTIBLES	
EDGE OF TOP TO CEILING	12" / 305 mm
BACK OF STOVE TO BACKWALL	3" / 75 mm
EDGE OF SIDE TO SIDEWALL	2" / 50 mm
EDGE OF TOP TO DIAGONAL WALL	2" / 50mm

ELECTRICAL RATING:
 115 VOLTS, LESS THAN 2.0A

Several Optional kits are available through HearthStone or your local HearthStone dealer. A blower assembly may be used (kit # 93-57010), two different remote controls (kit #90-56912 & kit #90-56914) are optional as well.

This appliance is only for use with the type of gas indicated on this rating plate and may be installed in an aftermarket, permanently located, manufactured (mobile) home where not prohibited by local codes. See owner's manual for details. This appliance is not convertible for use with other gases, unless a certified kit is used. If the vent air intake system is disassembled for any reason, reinstall per the instructions provided with the initial instructions. This vented gas fireplace heater is not for use with air filters.

VENTED GAS FIREPLACE HEATER - NOT FOR USE WITH SOLID FUEL.



MANUFACTURED BY: HearthStone, MORRISVILLE, VERMONT 05661

Date of Manufacture

2004	2005	2006	Jan	Feb	Mar	Apr	May	Jun	Jul	Aug	Sep	Oct	Nov	Dec
■	■	■	■	■	■	■	■	■	■	■	■	■	■	■

DO NOT REMOVE OR COVER THIS LABEL

MADE IN USA

3300-567

HEARTHSTONE GAS-FIRED STOVE AND INSERT LIMITED WARRANTIES

These warranties give you specific legal rights. You may also have other rights that vary from State to State.

HearthStone Quality Home Heating Products, Inc. (HearthStone) warrants **to the original purchaser only** (the “Original Purchaser”) the new gas-fired stove/insert manufactured by HearthStone and purchased by the Original Purchaser (referred to as the “Stove” for simplicity) against any of the occurrences listed in this document that result from defects in material or workmanship. All obligations of HearthStone under this document commence on the date the Original Purchaser purchases the Stove (the “Purchase Date”).

LIMITED LIFETIME WARRANTY

HearthStone warrants the following parts of the Stove against the following occurrences that result from defects in material and workmanship:

- All cast iron parts, including the cast iron heat exchanger – against breakage, cracking or burn-through.
- All stones – against cracking or breakage due to thermal stress, **excluding** surface and hairline cracks and scratches that do not affect the operation or safety of the Stove.
- Glass – against breakage due to thermal shock.

LIMITED FIVE-YEAR WARRANTY

HearthStone warrants the following parts of the Stove against the following occurrences that result from defects in material and workmanship:

- Firebox and firebox baffle – against breakage, cracking or burn-through.
- Convective heat exchanger – against breakage, cracking or burn-through.
- Burners, air shutters and orifices – against breakage, cracking or burn-through.
- Ceramic logs and embers – against breakage, cracking or burn-through.

This warranty expires on the fifth (5th) anniversary of the Purchase Date.

LIMITED THREE-YEAR WARRANTY

HearthStone warrants the following parts of the Stove against the following occurrences that result from defects in material and workmanship:

- Gas train, including gas valve, millivolt wiring, spill switch, pilot assembly, thermopile, thermocouple, piezo igniter, and, if the Stove is a vent-free model, ODS system – against breakage or malfunction.

This warranty expires on the third (3rd) anniversary of the Purchase Date.

LIMITED ONE-YEAR WARRANTY

HearthStone warrants the following parts of the Stove against the following occurrences that result from defects in material and workmanship:

- Enamel Finish – against peeling or fading, **excluding** chipping, mechanical abrasion, chemical abrasion or crazing.
- Gaskets and sealants – against breakage or deterioration.
- Accessories and electrical components such as blowers, switches and thermo discs, **excluding** venting components, hearth components, electrical components and other components or accessories used in conjunction with the installation of the Stove **not** manufactured or supplied by HearthStone – against breakage or malfunction.

This warranty expires on the first (1st) anniversary of the Purchase Date.

EXCLUSIONS

The warranties contained in this document do not cover, nor is HearthStone responsible for:

1. Damage resulting from installation or operation of the Stove in a manner contrary to the owner's manual.
2. Damage or non-performance resulting from faulty or incomplete setup, installation and start-up or mishandling, abuse, or misuse of the Stove, including but not limited to over-firing.
3. Damage resulting from installation, modification, alteration, repair or service of the Stove by any party other than HearthStone or an authorized HearthStone dealer (a "Dealer").
4. Damage due to water or due to installation of the Stove in a damp or high condensation area.
5. Damage due to installation of the Stove in an atmosphere contaminated by damaging chemicals, including but not limited to chlorine, fluorine or salts.
6. Scratches on glass, enameled surfaces or stones due to mechanical abrasion.
7. Standard wear and tear of the Stove resulting from normal usage over time.
8. Damage, operational-related problems, or inadequate performance caused by site, installation or environmental conditions beyond HearthStone's control, including but not limited to nearby trees, rooftops, buildings, wind, hills, mountains, inadequate or excessive venting, insufficient make up air, or negative air pressure whether or not caused by mechanical systems such as furnaces, exhaust fans, clothes dryers, etc.
9. A defect in any part of the Stove if the Original Purchaser fails to comply with HearthStone's or a Dealer's request to ship the part or the Stove to HearthStone or a Dealer, as the case may be.

THE WARRANTIES CONTAINED IN THIS DOCUMENT ARE EXCLUSIVE AND ARE GIVEN BY HEARTHSTONE AND ACCEPTED BY THE ORIGINAL PURCHASER IN LIEU OF ALL OTHER EXPRESS WARRANTIES AND ANY OBLIGATIONS, LIABILITIES, RIGHTS, CLAIMS, OR REMEDIES IN CONTRACT OR TORT, WHETHER OR NOT ARISING FROM HEARTHSTONE'S NEGLIGENCE, ACTUAL OR IMPUTED. ALL IMPLIED WARRANTIES, INCLUDING THE WARRANTIES OF MERCHANTABILITY AND FITNESS FOR A PARTICULAR PURPOSE, ARE GIVEN **ONLY** TO THE EXTENT REQUIRED BY FEDERAL OR STATE LAW. EXCEPT AS OTHERWISE REQUIRED BY STATE LAW, UPON THE EXPIRATION OF THE EXPRESS LIMITED WARRANTIES CONTAINED HEREIN, **NO** IMPLIED WARRANTIES, INCLUDING THE IMPLIED WARRANTIES OF MERCHANTABILITY OR FITNESS FOR A PARTICULAR PURPOSE, SHALL APPLY TO THE SUBJECT STOVE. **SOME STATES DO NOT ALLOW LIMITATIONS ON HOW LONG AN IMPLIED WARRANTY LASTS, SO THE ABOVE LIMITATION MAY NOT APPLY TO YOU.**

THE WARRANTIES CONTAINED IN THIS DOCUMENT EXTEND **ONLY** TO THE ORIGINAL PURCHASER OF THE STOVE WARRANTED HEREUNDER. THEY DO NOT EXTEND TO ANY SUBSEQUENT OWNERS.

UNDER NO CIRCUMSTANCES SHALL HEARTHSTONE BE LIABLE TO THE ORIGINAL PURCHASER OR ANY OTHER PERSON FOR ANY INCIDENTAL OR CONSEQUENTIAL DAMAGES, INCLUDING BUT NOT LIMITED TO DAMAGE TO PROPERTY OR PERSONAL INJURIES, WHETHER ARISING OUT OF BREACH OF WARRANTY, TORT, OR OTHERWISE, EVEN IF HEARTHSTONE HAS BEEN APPRAISED OF THE POSSIBILITY OF SUCH DAMAGES. **SOME STATES DO NOT ALLOW THE EXCLUSION OR LIMITATION OF INCIDENTAL OR CONSEQUENTIAL DAMAGES, SO THE ABOVE LIMITATION OR EXCLUSION MAY NOT APPLY TO YOU.**

QUALIFYING FOR WARRANTY COVERAGE

To obtain performance of any obligation under this document, the Original Purchaser must, **within the applicable warranty time period**, contact the HearthStone dealer from whom the purchase was made, or, if not applicable; HearthStone at the address listed in the Warranty Registration section below or at **(802) 888-5232**, for instructions regarding the return of defective parts for repair, the return of the Appliance for repair, or a Dealer service call. The Original Purchaser should refer to the Dealer network search engine contained on HearthStone's Web site (www.hearthstonestoves.com), or call HearthStone at (802) 888-5232, to find a Dealer nearest the Original Purchaser's location.

REMEDY

The remedy for any breach of the foregoing warranties will consist of repair or replacement, at HearthStone's option, of any covered defect in the Stove. When the Original Purchaser contacts HearthStone or a Dealer, HearthStone or the Dealer, as the case may be, will instruct the Original Purchaser to **either** return the defective part, or the entire Stove (if needed), with shipping prepaid, to HearthStone or a Dealer **or** allow a Dealer to make a service call at the place where the Stove is located. In the event the Original Purchaser refuses to allow a Dealer to make a service call, HearthStone or a Dealer, as the case may be, will request that the Original Owner return the defective part, or the entire Stove (if needed), with shipping prepaid, to HearthStone or a Dealer.

Notwithstanding any other provision of this document, the Original Purchaser shall pay for any travel fees and service charges related to a Dealer's service call.

Parts: HearthStone will replace defective parts covered by the foregoing warranties at no charge.

Labor: Within the first (1st) year after the Purchase Date, HearthStone will pay for warranty labor performed by a Dealer at HearthStone's published labor rates in effect at the time the labor is performed. Thereafter, the Original Purchaser is responsible for the cost of labor.

Shipping cost for parts: Within the first ninety (90) days after the Purchase Date, HearthStone will pay for the shipping of Stove parts covered by any of the foregoing warranties to and from HearthStone or a Dealer, as the case may be. Thereafter, the Original Purchaser is responsible for all shipping costs related to shipping Stove parts to and from HearthStone or a Dealer, as the case may be.

Shipping cost for the Stove: Within the first (1st) year after the Purchase Date, if the Original Purchaser is instructed to return the Stove to HearthStone or a Dealer for repair, HearthStone will pay fifty percent (50%) and the Original Purchaser will pay fifty percent (50%) of the shipping costs related to shipping the Stove to and from HearthStone or a Dealer, as the case may be. Thereafter, the Original Purchaser is responsible for one hundred percent (100%) of all of the shipping costs related to shipping the Stove to and from HearthStone or a Dealer, as the case may be. Notwithstanding any other provision of this document, in no event will HearthStone pay for any Dealer fees or other fees for pick up or delivery of the Stove returned for repair; the Original Purchaser shall be responsible for any such fees.

WARRANTY REGISTRATION

The Original Purchaser may send a completed and signed Warranty Registration Form, which is enclosed in the Stove warranty packet, to the following address:

HearthStone Quality Home Heating Products, Inc.
Warranty Department
317 Stafford Avenue
Morrisville, VT 05661-8695

NOTE: SENDING IN THE SIGNED WARRANTY REGISTRATION FORM IS NOT A CONDITION OF WARRANTY COVERAGE OR HEARTHSTONE'S PERFORMANCE.