

# Owner's Manual & Installation Guide

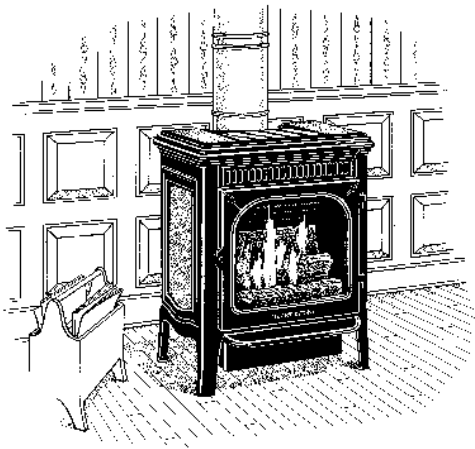

for the **Tucson** (8720) GAS-FIRED  
B-VENT HEATER



## READ THIS OWNER'S MANUAL

Operate and maintain this gas heater  
according to this instruction manual.  
**Read This Manual In Its Entirety.**

**WARNING:** If the information in these instructions is not followed exactly, a fire or explosion may result causing property damage, personal injury or loss of life.

Do not store or use gasoline or other flammable vapors and liquids in the vicinity of this or any other appliance.

### WHAT TO DO IF YOU SMELL GAS:

- Do not try to light any appliance.
- Do not touch electrical switches; do not use the phone in your building.
- Immediately call your gas supplier from a neighbors phone. Follow your gas suppliers instructions.
- If you cannot reach your gas supplier, call the fire department.

A qualified installer, service agency or gas supplier must perform installation and service.

**AVERTISSEMENT:** Assurez-vous de bien suivre les instructions donné dans cette notice pour réduire au minimum le risque d'incendie ou pour éviter tout dommage matériel, toute blessure ou la mort.

Ne pas entresposer ni utiliser d'essence ni d'autre vaperurs ou liquides inflammables dans le voisinage de cet appareil ou de tout autre appareil.

### QUE FAIRE SI VOUS SENTEZ UNE ODEUR DE GAZ:

- Ne pas tenter d'allumer d'appareil.
- Ne touchez à aucun interrupteur. Ne pas vous servir des téléphones se trouvant dans le bâtiment où vous vous trouvez.
- Appelez immédiatement votre fournisseur de gaz depuis un voisin. Suivez les instructions du fournisseur.
- Si vous ne pouvez rejoindre le fournisseur de gaz, appelez le service dos incendies.

L'installation et service doit être exécuté par un qualifié installer, agence de service ou le fournisseur de gaz.



Model #8720  
6400-40433  
11-24-04



## INTRODUCTION

Congratulations on your purchase of a Tucson Gas-Fired B-Vent heater. The Tucson, by HearthStone, incorporates the latest in gas technology, which will provide you with clean, efficient heat for years to come. The combination of natural stones and cast iron gives the Tucson a pleasing look that can be maintained with minimum care.

The Tucson will provide you with years of practical and convenient service. However, as with any gas appliance, the unit must be properly and safely installed and maintained by qualified service personnel to ensure safe and trouble-free operation.

Your Tucson is equipped with a standard pilot which:

1. generates a milli-volt signal that powers the wall-mounted thermostat and;
2. lights the main burner when the thermostat calls for heat.

This unit is equipped with an On/Off/T'stat switch and a variable output control. The variable output control is located on the gas control valve. It allows you to vary the heat output, along with the flame height to suit personal taste. Heat output can be reduced {set to "LOW"} during the Fall and Spring, when the need for heat is reduced and increased {set to "HIGH"} during Winter months, when the need for heat is the greatest.

A wall-mounted thermostat is provided by HearthStone. Regardless of how you set the variable output control, when the optional thermostat has been installed and the On/Off/T'stat switch is set to "T'stat", the wall-mounted thermostat will control the

on/off cycling of the unit. At any time, you can override the thermostat with the On/Off/T'stat switch by setting it to "ON" or "OFF".

The Unit can also be equipped with an optional blower fan, which turns on and off independently of the burner flames. When the switch, which allows you to turn the fan on or off and control the speed of the fan to suit your needs, is set to "High" or "Lo", the fan will automatically turn on when the stove is hot and cycle off when the unit is no longer hot.

Also available are two different optional remote controls. Both of the remote controls are capable of turning the unit on and off. One of the optional remotes also allows you to control the temperature of the stove from anywhere in the vicinity of the unit. If "ON" & "OFF" are the only controls required, Kit # 90-56912 can be used. If you would like to control the temperature via the remote control, use Kit # 90-56914.

## READ THIS OWNER'S MANUAL

Operate and maintain this gas heater according to the instructions in this manual. Read this manual in its entirety. This manual has two sections, the first section is for the *OPERATOR*, and the second section is for the *QUALIFIED SERVICE PERSONNEL* only.

## HEATER MUST BE INSTALLED AND MAINTAINED BY QUALIFIED SERVICE PERSONNEL

Verify the gas connections and venting systems with requirements of local, regional or national installation codes. Qualified service personnel must inspect the gas heater before use and at least annually.

## TABLE OF CONTENTS

<b>READ THIS OWNER’S MANUAL.....</b>	<b>1</b>
<b>INTRODUCTION.....</b>	<b>3</b>
<b>SAFETY INFORMATION.....</b>	<b>4</b>
<b>SPECIFICATIONS:.....</b>	<b>8</b>
<b>OWNER’S INFORMATION.....</b>	<b>9</b>
<b>ROUTINE MAINTENANCE AND CARE.....</b>	<b>9</b>
<b>INSTALLER’S INFORMATION.....</b>	<b>12</b>
UNPACK AND INSPECT FOR DAMAGE.....	13
<b>ELECTRICAL CONNECTIONS.....</b>	<b>18</b>
<b>GAS SUPPLY &amp; CONNECTIONS.....</b>	<b>20</b>
<b>LOG PLACEMENT.....</b>	<b>21</b>
<b>INITIAL ADJUSTMENTS.....</b>	<b>24</b>
<b>PARTS LISTS.....</b>	<b>28</b>

## SAFETY INFORMATION

Your Tucson is a very attractive and extremely efficient, utilizing today’s best technologies. By following a few simple safety precautions and by performing minimal maintenance, the unit will remain appealing while providing years of quality performance.

The installation must conform to local codes or, in the absence of local codes, the current National Fuel Gas Code, ANSI Z223.1 (NFPA 54) or CAN/CGA B149 Installation Code. (*Installer l’appareil selon les codes ou règlements locaux, ou, en l’absence de tels règlements, selon les Codes d’installation CAN/CGA B149.*)

During the first few hours of operation the appliance may produce a slight smoke and/or odor. This is normal during the first several burns. During the initial burn, open a window(s) to assist in the removal of the

smoke/odor. If the logs appear to smoke, turn the heater off and call a qualified service technician.

The appliance and its individual shutoff valve must be disconnected from the gas supply piping system during any pressure testing of that system at test pressures in excess of ½ psig. (3.5k Pa). The appliance must be isolated from the gas supply piping system by closing its individual manual shutoff valve during any pressure testing of the gas supply piping system at test pressures equal to or less than ½ psig (3.5k Pa).

### FIRE HAZARD

Do not store or use gasoline or other flammable vapors or liquids in the vicinity of this appliance. The Tucson should be located out of traffic and away from furniture, draperies, clothing, and flammable material.

### SHOCK HAZARD

(When equipped with an optional blower)  
This appliance is equipped with a three-prong (grounding) plug for protection against shock hazard and should be plugged directly into a properly grounded three-prong receptacle. Do not cut or remove the grounding prong from the plug.

### MUST BE VENTED TO THE OUTSIDE

Never vent the gas heater to other rooms or buildings. This gas appliance must not be connected to a chimney flue serving a separate solid-fuel burning appliance.

### SERVICE CAUTION

If you believe your Tucson is not, in any way, performing properly, immediately discontinue operation until the unit has been inspected and approved by qualified service personnel. Prior to servicing the unit, turn

the valve control knob clockwise to “OFF”. The unit should be cool prior to servicing and cleaning. Any safety screen, guard, or component removed during servicing should be replaced prior to operation. Use of any components not supplied by HearthStone on the stove voids all warranties. **Do not substitute components.**

## HOT SURFACES

Certain exposed surfaces of the Tucson will reach high temperatures during normal operation. Clearances to combustibles must be maintained, as specified in the “Clearances To Combustibles” section of this manual. **Due to high temperatures the appliance should be located out of traffic and away from furniture, draperies, clothing and flammable materials. Children and adults should be alerted to the hazards of high surface temperatures and should stay away to avoid burns to skin or clothing ignition. Young children should be carefully**

- › **WARNING: DO NOT OPERATE THE APPLIANCE WITH THE FRONT GLASS REMOVED, CRACKED OR BROKEN. REPLACEMENT OF GLASS SHOULD BE DONE BY A LICENSED OR QUALIFIED SERVICE PERSON. ONLY OPEN FRONT FOR ROUTINE SERVICE. DO NOT SLAM OR STRIKE GLASS.**

## CERAMIC FIBER LOG SAFETY INFORMATION

If the decorative ceramic log material supplied with the Tucson is damaged or missing, it must be replaced with the same, approved replacement parts supplied by the manufacturer. These components affect the combustion quality and safety of the heater. Do not replace fiber ceramic logs with unapproved ceramic logs or any other material.

**supervised when in the same room as the appliance. Clothing or other flammable material should not be placed on or near the appliance.** (*Surveille les enfants. Garder les vêtements, les meubles, l'essence ou autres liquides à vapeur inflammables lin de l'appareil.*) Clean the area around, under, and behind the unit on a regular basis to prevent the accumulation of dust and lint.

## NEVER BURN PAPER, WOOD OR OTHER MATERIALS

This gas heater is designed to burn natural gas or liquid propane (LP). Never burn any fuel not intended for use with this unit.

## WARNING

This gas appliance must not be connected to a chimney flue serving a separate solid-fuel burning appliance

**Always wear gloves and safety goggles while handling the log set and ember strip.**

## !ELECTRICAL HAZARD!

When the optional blower kit is installed, the Tucson must be electrically grounded in accordance with local codes, or in the absence of local codes, with the National Electrical Code, ANSI/NFPA 70 in the U.S. or CSA C22.1 Canadian Electrical Code in Canada. The Tucson fan accessory is equipped with two blower fans. The three-prong grounded plug must be plugged directly into a properly grounded three-prong receptacle. Do not cut or remove the

grounding prong from the plug or otherwise attempt to circumvent the grounding protection provided with the unit.

### **DO NOT LIGHT PILOT OR MAIN BURNERS BY HAND**

The standing pilot light equipped on this gas heater is lit by using a piezoelectric spark generator as described elsewhere in this manual. Never attempt to light the pilot or main burners by hand with a match or lighter. If, after repeated attempts, the pilot light fails to light, discontinue operation, turn off the gas at the gas control valve, and immediately contact qualified service personnel for assistance.

#### **Certified for use by:**

Board of State Examiners of Plumbers and Gasfitters  
100 Cambridge Street, Room 1511  
Boston, Massachusetts  
02202

## MOBILE HOME INSTALLATIONS

This appliance may be installed in an aftermarket, permanently located, manufactured (mobile) home, where not prohibited by local codes.

This appliance is only for use with the type(s) of gas indicated on the rating plate. This appliance is not convertible for use with other gases, unless a certified kit is used.

*(Cet appareil peut être installé dans un maison préfabriquée (mobile) déjà installée à demeure si les règlements locaux le permettent.*

*Cet appareil doit être utilisé uniquement avec les types de gas indiqués sur la plaque signalétique. Ne pas l'utiliser avec d'autres gas sauf si un kited conversion certifié est installé.)*

## SERVICE CAUTION

Any shield, door, or safety screen component removed for servicing will be replaced prior to operating. If you believe your Tucson is not performing properly in any way what so ever, immediately discontinue operation until the unit has been inspected by qualified service personnel. Always shut off the gas and electricity to the stove while servicing. Make sure the unit is not hot when servicing or cleaning. Use of any components not supplied by HearthStone on the stove or vent system voids all warranties. Do not substitute components.

HearthStone  
Quality Home Heating Products  
317 Stafford Avenue,  
Morrisville, Vermont 05661  
E-Mail: [Inquiry@HearthStoneStoves.com](mailto:Inquiry@HearthStoneStoves.com)

## SPECIFICATIONS:

### LISTED: B-VENT GAS HEATER

**Listed:** Gas-Fired B-Vent Fireplace Heater

**Model:** Tucson B-Vent Gas Fireplace Heater

**Testing Agency:** Intertek Testing Services NA Inc. (ITS)

**Tested to:** ANSI Z21.88-2002, CSA 2.33-M02, CAN/CGA2.17-M91  
Certified for Canada

Approved for

Mobile Home Installation (see page 7)

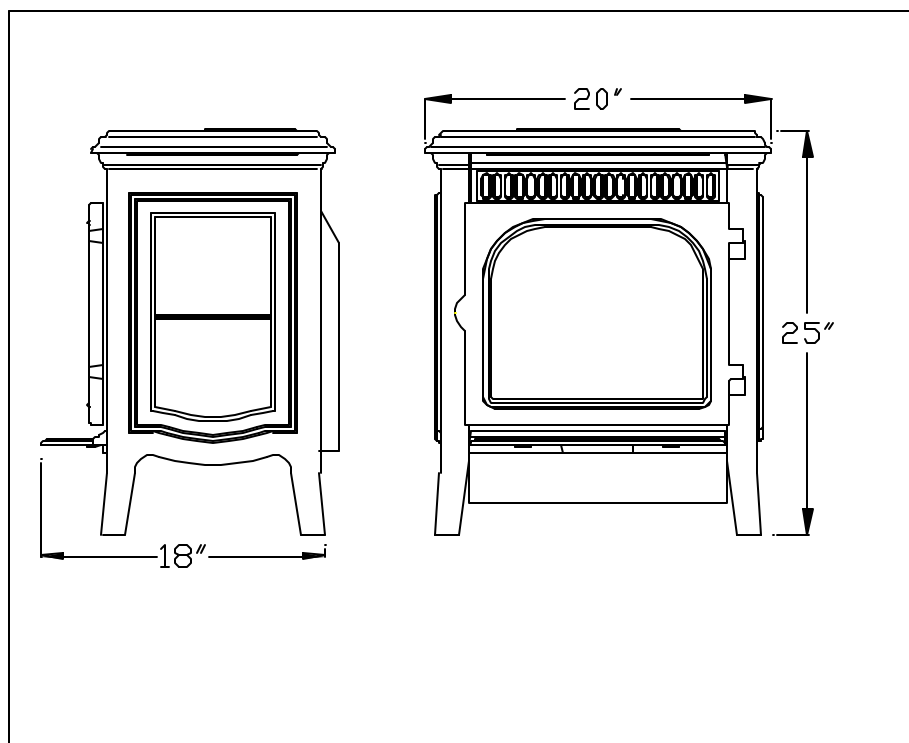

Figure 1: Tucson Dimensions

	NG	LP
Input rating (Btu/hr) 0-1370 m	26,000	26,000
Maximum output (Btu/hr) 0-1370 m	20,000	20,500
Minimum input rating (Btu/hr)	14,700	14,700
Orifice size DMS 0-1370 m	40	53
Man. pressure- HI setting (in.w.c./kPa)	3.5/0.9	10.0/2.5
Man. pressure- LO setting (in.w.c./kPa)	1.2/0.3	3.3/0.8
Inlet pressure-Lo (in.w.c./kPa)	5.0/1.25	11.0/2.75

## OWNER'S INFORMATION

### DAILY OPERATION

The Tucson gas-fired heater is easily operated by the homeowner once installed and adjusted by qualified service personnel. The unit is controlled via the wall-mounted thermostat during the heating season. Set the thermostat to the desired room temperature and the unit will cycle on and off as required. By adjusting the variable output control located on the gas control valve, the rate of heat output can be varied to meet the heating requirements of the season. Choosing a low flame setting will result in longer burn cycles at a reduced output, while choosing a high flame setting will result in a shorter, hotter burn cycle. Through trial and error, the homeowner can select the optimum flame size for their setting and application.

During the summer non-heating season, switch the wall thermostat to "OFF", and turn off the pilot. This will improve the overall efficiency of the unit as the heat from the pilot is wasted. When putting the unit back into service, follow the lighting instructions described on page 24.

When the unit is first lit, especially when cool, it is normal to experience some condensation on the inside of the window glass. This condensation will burn off within the first few minutes of operation. If continuous condensation on the window glass or dripping water from any part of the unit or venting system (chimney) is noted, immediately discontinue operation of the unit and contact qualified service personnel.

## ROUTINE MAINTENANCE AND CARE

The Tucson requires minimal routine maintenance and care. The unit should always be cool and off when being cleaned.

### CLEANING

- › **WARNING: Do not clean the unit when hot.** The unit should receive regular cleaning on, under, and around the stove to prevent the buildup of dust and lint. The exterior surfaces of the unit can be cleaned using soap, water, and a soft cloth. **Do not** use abrasive or chemical cleaners and take care not to scratch the glass or enamel finish (if so equipped) when cleaning the unit. The use of chemical wax based cleaners or polishes are not recommended due to the potential for discoloration or the enamel when the residue of the cleaners or polishes is exposed to heat.

## FIREBOX, PILOT, & BURNER TUBES

The firebox should receive periodic cleaning to prevent the accumulation of dust, lint, and other debris. To clean the firebox, set the thermostat to the “OFF” position, and turn off the gas at the gas control valve. When the unit is cool, unfasten the front door and carefully remove the decorative ceramic fiber log set, taking care not to damage the logs or chip the enamel cast iron. Clean the firebox burner tube and carefully vacuum the entire surface of the log set. Thoroughly vacuum the ports (holes) along the top of the burner tubes.

With the decorative ceramic fiber logs out of the firebox, fasten the door shut and momentarily light the unit according to the lighting instructions described on page 24. Check to insure a flame is burning from each burner port. The pilot flame should be large enough to engulf the sensor/thermocouple. Turn the unit off by setting the thermostat to “OFF” and turning off the gas control valve. Allow the unit to cool. Check and clean any burner ports that are not burning or not burning properly. Clean burner ports using soft a soft brush or vacuum cleaner. If the pilot flame height needs adjustment, it should be adjusted by qualified service personnel as described on page 26.

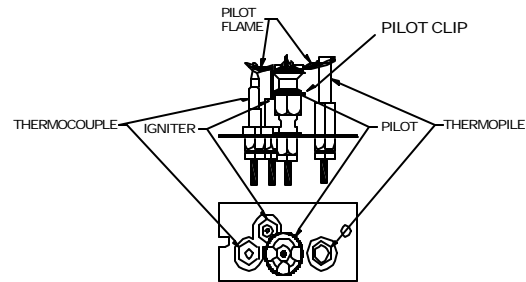

**Figure 2: Pilot Assembly**

Complete the cleaning procedure by carefully placing the log set within the firebox as described on page 21. Close and fasten the front door. Turn on the gas, light the unit and check for proper operation. Flame patterns should look like Figure 3. Regularly check to insure the area around the Tucson is kept free from combustible materials, gasoline, and other flammable vapors and liquids. Check that the flow of combustion and ventilation air is not obstructed. Once a year the unit and venting system should be inspected by qualified service personnel to insure that they are clean, free of obstruction, safe, and in good working order. If service or maintenance is required, it should be performed by qualified service personnel.

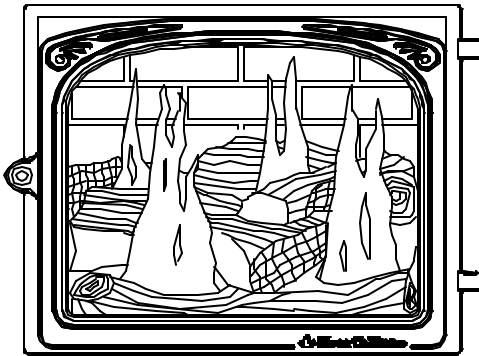

Figure 3: Burner Flame Pattern

## REPLACE THE FRONT DOOR GASKET AS NEEDED

Your Tucson uses a 3/8" rope-type fiberglass gasket to make a tight seal between the door frame and the firebox. In time, the gasket can become brittle and compressed and should be replaced. New gasket material is available from your Authorized HearthStone Dealer.

1. Allow the Tucson to cool completely. Remove the existing gasket by grasping one end and pulling firmly.
2. Use a wire brush or the tip of a screwdriver to clean the channel of remaining gasket.
3. Determine the correct length of the appropriate-sized gasket by laying it out in the channel. Allow an extra 1 to 2" (25-50mm), and mark the spot to be cut.
4. Cut the gasket at the marked spot with a utility knife. Twist the ends slightly to prevent the gasket from unraveling.
5. Apply water glass adhesive to the gasket channel.
6. Starting at one end, press the gasket into the channel. Insure a good joint where

the gasket ends meet before trimming any excess. Do not overlap the gasket ends or leave ends with ragged edges.

7. Firmly and evenly press the gasket to seat it in its channel.

## CLASS CLEANING

If operating with propane, it may be necessary to clean the inside of the glass occasionally. Do not use abrasive cleaners. Do not clean the glass when hot. Allow glass to cool and apply a window cleaning fluid.

- › **WARNING:** Do not operate this appliance with the glass panel removed, cracked, or broken. Do not subject the door to abuse, such as striking or slamming shut. Replacement of the glass panel should be done by a licensed or qualified service person.

## INSTALLER'S INFORMATION CODES

Adhere to all **local codes** or, in their absence, the latest edition of **THE NATIONAL FUEL GAS CODE ANSI Z223.1 (NFPA 54)** or **CAN/CGA B149** Installation Code that can be obtained from:

**AMERICAN NATIONAL STANDARDS  
INSTITUTE, INC.**  
1430 BROADWAY  
NEW YORK, NY 10018  
OR  
**NATIONAL FIRE PROTECTION  
ASSOCIATION, INC.**  
BATTERY MARCH PARK  
QUINCY, MA 02269

The appliance when installed, must be electrically connected and grounded in accordance with local codes or, in the absence of local codes, with the current NFPA 70-National Electrical Code or CSA C22.1-Canadian Electric Code.

A manufactured home (mobile) OEM installation must conform with the Manufactured Home Construction and Safety Standard, Title 24 CFR, Part 3280 (U.S.) or Standard for Manufactured Home Installation, ANSI/NCBCS A225.1 or Standard for Gas Equipped Recreational Vehicles and mobile Housing, CSA Z240.4.CAN/SCA Z240 MH (Canada). (*Installer l'appareil selon les codes ou règlements locaux, ou, en l'absence de tels règlements, selon les Codes d'installation CAN/CGA-B149.*)

## ITEMS REQUIRED FOR INSTALLATION

- \* External regulator (for propane/L.P.G. only)
- \* Piping which complies with local codes
- \* Pipe sealant approved for use with propane/L.P.G. (resistant to sulfur compounds)
- \* Manual shutoff valve
- \* Sediment trap
- \* Tee joint
- \* Pipe wrench
- \* Phillips head screwdriver
- \* Other parts as required by local code
- \* Safety Glasses
- \* Gloves

## PACKING LIST

- 1-Tucson Gas-Fired Heater
- 2-Decorative Ceramic Fiber Logs
- 2-Ember Screens
- 1-Charcoal Embers
- 1-Owner's Manual
- 1-Thermostat
- 1-40' Thermostat wire
- 1-L.P. Fuel Conversion Kit
- 1-Warranty Validation Form
- 1- Stone Set (installation instructions included in kit)

Note: Vent kits are supplied separately. Failure to use the venting components suggested by HearthStone will void your warranty.

## UNPACKING AND INSPECTION

### UNPACK AND INSPECT FOR DAMAGE

The Tucson is packaged by the manufacturer to withstand shipment without damage. However, damage can occur during transit so take care to inspect for damage when unpacking and installing the unit. If any damage or missing parts are detected, immediately contact your dealer. **Do not install or put into service a damaged or incomplete heater.**

The stone set will be packaged separately. Carefully remove and set aside the stones. Use the protective wrapping material to temporarily protect the stones from chipping and damage while the unit is inspected and installed.

Inspect the Tucson for visible or concealed damage. The unit should appear to be square and true. The stones should be whole and without cracks, chips, or breakage. The sheet metal parts should be smooth and free of bends and dents. The enameled cast iron should be free of chips or cracks. If visible or concealed damage is found or suspected, contact your dealer for instructions.

With the top grill removed and set aside, undo the lag bolts that fasten the unit to the pallet. Take care not to mar or chip the enameled legs. Lift the stove off the pallet and set it into place.

The decorative ceramic fiber logs supplied with the Tucson are contained within the firebox. Always use great care when handling the decorative ceramic fire logs as they are fragile and subject to damage and breakage if handled roughly. Open the firebox door using a 5/32" allen wrench screwdriver and inspect the logs for damage. If a broken log is encountered, contact your dealer for replacement logs. Otherwise, set

the logs aside until called for during the installation.

To install the stones, use the instructions that are supplied with the stone set.

## HEARTH REQUIREMENT/FLOOR PROTECTION

The Tucson may be placed on a non-combustible surface or wood floor. For placement of the Tucson on carpeting, vinyl tile or other combustible materials, the appliance shall be installed on a metal or wood panel extending the full width and depth of the appliance. Installations must meet local codes.

## CLEARANCE TO COMBUSTIBLES

Due to high surface temperatures, the unit should be located out of traffic and away from furniture and draperies. Clothing and other flammable material should not be placed on or near the heater. When positioning the unit always maintain adequate clearances around air openings into the combustion chamber and allow for adequate ventilation. Minimum clearances to combustibles must be maintained as shown in the illustrations in figures 4-7.

Note: The rear clearance to combustibles will be determined by either the unit's or the vent pipe's minimum clearance, (A refer to Figures 6+7) depending on whether the installation calls for vertical rise within the room or a rear exit, through-the-wall vent pipe.

Be sure to consider the need for access to the gas control valve access door on the front of the unit as well as full access for periodic cleaning and servicing. Also consider the location of the Optional Blower Fan.

**NOTE:** These clearances represent *minimum* distances in all cases, which, through testing in an independent laboratory to ANSI and CSA standards, will prevent fire or spontaneous combustion. We do not control the combustible materials exposed to heat by this product; therefore, an assessment must be made by the installer to prevent consequential damage of walls and flooring.

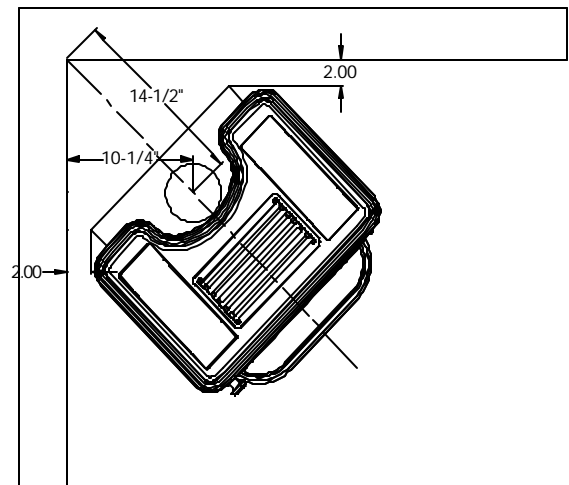

Figure 4: Corner Clearances to Combustibles

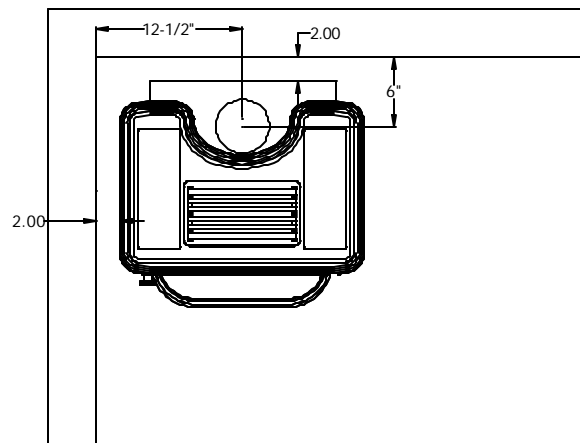

Figure 5: Minimum Wall Clearance To Combustibles

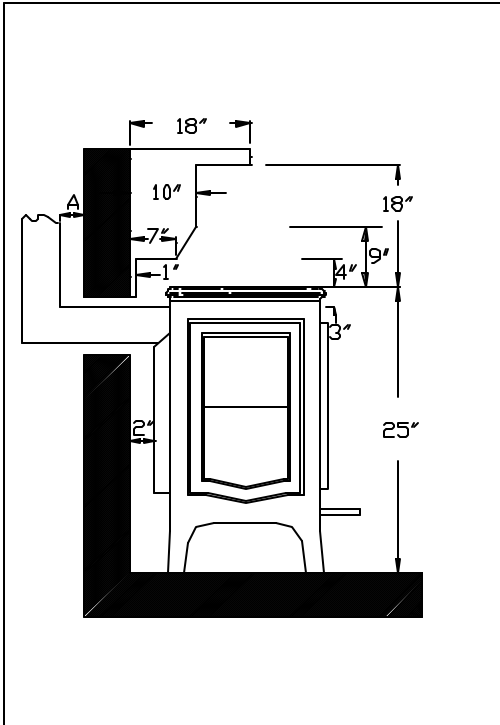

Figure 6: Mantle Clearance To Combustibles

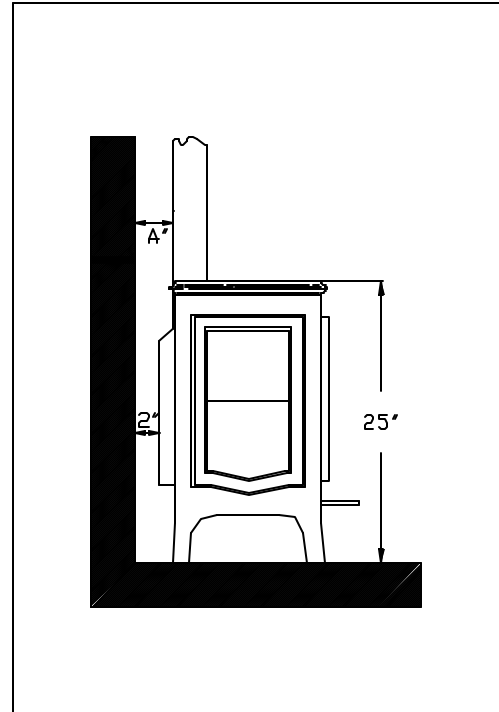

Figure 7: Wall Clearance To Combustibles

## Venting

### Normally Aspirating Chimneys

The Tucson is a highly efficient gas heater. With operating efficiency as high as **82%**, most heat output is retained within the living space, with minimal heat leaving the room via the chimney. However, some heat is required in all chimneys in order to establish and maintain a draft. Since most of the heat is retained in the living space with minimal heat entering the chimney, it is imperative that the chimney/venting system be properly sized and installed in order to establish and maintain the draft required for the unit to function.

The Tucson must be properly connected to a 4" (102 mm) diameter type B-1 vent which is constructed and installed in accordance with NFPA54 and NFPA211. Single wall

vent pipe may be used within the same room as the Tucson so long as adequate (6" or 152 mm) clearance is maintained from the single wall pipe to combustible surfaces. The single wall vent pipe **must** connect to double-wall type B-1 vent from thereon. The minimum clearance from type B-1 vent to combustibles is 1"(25 mm).

Connect the single wall or B-1 vent pipe to the flue collar located on the rear surface of the unit using 3 sheet metal screws. For wall, roof or partition penetration, refer to the current edition of ANSI Z223.1 or CAN1-B149 for instructions and clearances to combustibles. The Tucson can be connected to an existing, properly constructed masonry or prefabricated chimney so long as the type B-1 vent is extended through the entire length of the chimney. An annual inspection is required to

confirm that the vent is unobstructed. The vent can not be connected with a flue serving a solid fuel appliance. It however, can be installed to a flue serving another gas or oil appliance, so long as it is in accordance with the National Fuel Gas Code.

Type B-1 vent pipe is intended primarily for installation inside buildings to provide an essentially vertical passageway for flue gases from the vented gas appliance to the outside air. When it is impractical to install B-1 vent pipe inside a building, it may be installed outdoors provided that it is: 1) certified for outside installation, 2) installed in accordance with manufacturer's installation instructions and 3) adequately chased (enclosed) and insulated (per Venting Tables, Category I-Central Furnaces, AGA and GAMA current edition; Standards for Gas Vents, National Standards of Canada and CAN/CGA-B149.1-M91). Exterior B-1 vent pipe passing through an unused masonry chimney flue is not considered to be exposed to the outdoors.

Four-inch flexible pipe can be used in place of B-1 vent pipe wherever it is impractical or impossible to install rigid Type B-1 vent pipe. However, flexible pipe is less desirable than B-1 vent pipe, because there is a greater heat loss along the length of flex pipe, which may produce an unacceptable draft

### **Draft Hood/Down Draft Sensor/Spill Switch**

The Tucson has a draft hood as part of its rear assembly. The draft hood must not be altered or obstructed. The Tucson must be installed so that the draft hood is in the same atmospheric pressure zone as the combustible air inlet for the unit. The Tucson cannot and must not be connected to

an outside air source; the unit must take its combustion air from the living space in which it is installed. The draft hood is equipped with a safety shutoff down draft sensor switch (spill switch), which is located in the draft hood just beneath the flue collar on the rear of the unit. This switch is designed to sense a loss of draft within the chimney. The down draft sensor switch is wired in series with the pilot thermocouple and is typically in the closed position.

Should the Tucson fail to establish or lose draft while in operation, hot exhaust gasses will spill into the room through the bottom of the draft hood instead of exiting the draft hood via the flue collar and venting to the outdoors. When this undesirable down draft condition occurs the hot gasses spilling out of the draft hood will heat the spill switch causing it to open, which turns the unit off.

Do not modify, disconnect or otherwise defeat the purpose of the down draft sensor switch. If your stove shuts off during normal operation, it is indicative of an unsafe venting condition, which must be corrected. Operation of this unit when not properly connected to a properly installed and maintained venting system or tampering with the vent safety shutoff system can result in carbon monoxide (CO) poisoning and possible death.

### **Power Venting**

For applications where it is impractical or impossible to exit B-1 vent pipe to above the existing roof line, the Tucson can be vented using a power vent. A power vent is essentially a specialized electric fan mounted on the outer wall of the building, which is connected to the heater via the flue pipe. When the thermostat calls for heat, the power vent turns on and creates a draft in the flue pipe similar to the draft created by a properly functioning conventional chimney.

The Tucson operates in a normal fashion, satisfied by the simulated draft. A series of interlocking safety devices prevents operation of the heater unless the power vent is operating properly. Both the Tucson and the power vent are controlled by the wall

thermostat and neither will operate if there is a power failure. For installations requiring power venting, use only an AGA (U.S.) Or CGA (CANADA) listed unit. The power vent supplier will in turn supply the power vent installations.

## ELECTRICAL CONNECTIONS

**NOTE:** OPEN VALVE DOOR UNDER THE ASH LIP FOR ELECTRICAL AND GAS CONNECTIONS.

### THERMOSTAT

The ON/OFF/T'stat switch or wall mounted thermostat controls the Tucson. We recommend installation of the thermostat for more comfortable performance, however you may still override the thermostat by setting the switch to "ON". The thermostat controls the unit by "calling for heat." The thermostat turns the unit on when the room is cold, and turns the unit off once the room is warmed sufficiently. The thermostat is controlled by a 750 millivolt DC two-wire circuit.

### REMOTE CONTROL

There are two different optional remote controls. Both of the remote controls are capable of turning the unit on and off. One of the optional remotes also allows you to control the temperature of the stove, (in the same way the thermostat controls the heater), from anywhere in the vicinity of the unit. If "ON" & "OFF" are the only controls required, Kit #90-56912 can be used. If you would like to control the temperature via the remote control, use Kit #90-56914. Installation instructions are provided with the kits.

### THERMOSTAT PLACEMENT

The thermostat should be placed in the same room or living space as the unit. Typically 5' (1.5m) off the floor and away from any influences that may cause the temperature in the vicinity of the thermostat to be unrepresentative of the room temperature in general. Such influences might include strong lighting, a heater vent from the

central heating system, or a nearby drafty window.

Placement of the thermostat on an inside wall rather than an outside wall is preferable. Do not place the thermostat directly behind or too close to the unit, otherwise heat from the unit will immediately satisfy the thermostat and turn the unit off.

### THERMOSTAT WIRING

**When installing the thermostat, do not cut and splice the thermostat wire. This will create a voltage drop that will cause your unit to run improperly**

The thermostat should be connected to the Tucson using no more than 40' (12 m) of the provided insulated thermostat wire. Be sure to leave a small coil of thermostat wire behind the Tucson so that the unit can be moved out of position for servicing and cleaning.

Connect one of the thermostat wires to the gas control marked **TH** and the other to the yellow wire coming from the on/off T'stat switch. When making these connections, position the thermostat wire so that it extends towards the wall behind the Tucson, then towards the thermostat.

At the thermostat, the wires should be connected to the two connection screws on the back of the thermostat per the instructions received with the thermostat. Take care not to over-tighten the connection screws and not to damage the internal parts of the thermostat.

### WIRING INSTRUCTIONS

- › **CAUTION:** Label all wires prior to disconnection when servicing controls. Wiring errors can cause improper and dangerous operation. Verify proper operation after servicing. (Attention: Au moment de l'entretien des commandes, étiquetez tous les fils avant le débranchement. Des erreurs de câblage peuvent entraîner un fonctionnement inadéquat et dangereux.) The proper location of wire connections is shown in Figure 8.

## Wiring Diagram - Tucson

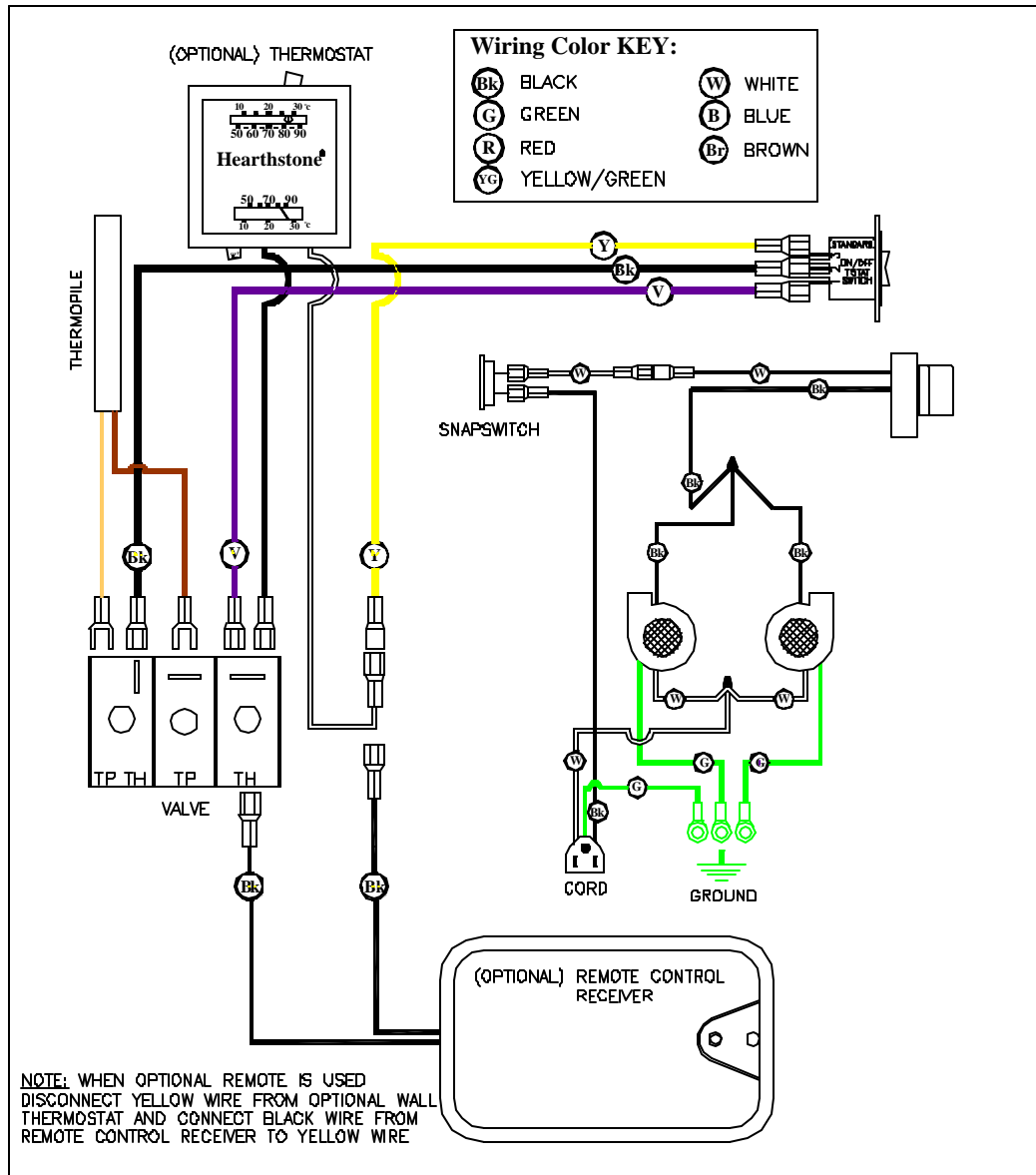

Figure 8: Wiring Diagram

NOTE: If an optional blower is to be installed now or in the future, make sure the gas line is installed as close to the floor as possible.

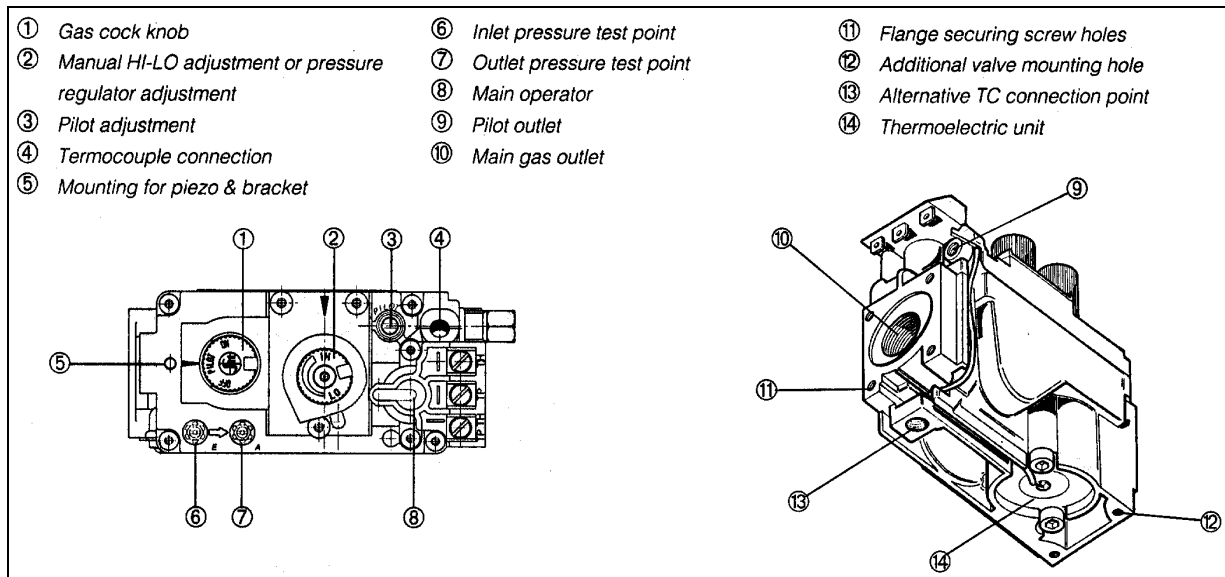

Figure 9: Gas Control Valve

## GAS SUPPLY & CONNECTIONS

- › **NOTICE:** A qualified technician must connect the heater to the gas supply and leak test the unit before it is approved for use. Consult all codes.
- › **WARNING:** The unit must be installed and connected in accordance with local codes, or in the absence of local codes, with the most current edition of the National Fuel Gas Code ANSI Z223.1 (NFPA 54) or CAN/CGA B149 Installation Code.

### GAS CONNECTIONS

The gas supply line connection is made to the Tucson's gas control valve just inside the left front leg of the unit using a 3/8" male NPT fitting. The supply line should be 1/2" diameter or appropriately sized to provide a sufficient gas supply to meet the

maximum demand of the unit without undue loss of pressure. We recommend a flexible line to avoid undue mechanical load on the valve and to ease thread alignment, but refer to local codes.

- › **CAUTION: Check Gas Type!**

### GAS SUPPLY

This appliance and its individual shutoff valve must be disconnected from the gas supply piping system during any pressure testing of that system at test pressures in excess of 1/2 psig. The Tucson must be isolated from the gas supply piping system by closing its individual manual shutoff valve during any pressure testing of the gas supply piping system at test pressures equal to or greater than 1/2 psig.

### GAS PRESSURE ADJUSTMENT

**NOTE: A QUALIFIED TECHNICIAN MUST PERFORM THIS PROCEDURE!**

Once connected to the gas supply, the supply line and manifold gas pressures must be tested. The supply line pressure is tested, to insure it meets the minimum gas supply pressure as listed in the Specifications for the type of fuel in use (natural gas or LP), by connecting a manometer to the supply line and adjusting the incoming pressure if necessary to meet the required supply line pressure as listed in specifications. The manifold pressure tap on the gas control valve, refer to Figure 9 for location.

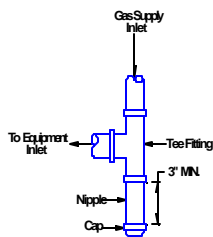

Figure 10 Sediment Trap (Required)

## LOG PLACEMENT

**CAUTION:** Fragile! Handle log set with care. Always wear gloves and safety goggles while handling the log set.

Only the decorative ceramic fiber log set supplied with the unit should be placed in the firebox. Do not place any other ceramic logs, wood logs, or other materials in the firebox. If the log set is damaged or broken contact your dealer for replacement. The decorative ceramic fiber log set will last a long time, however, they will break if subjected to rough or improper handling. Exact positioning of the log set is required in order to obtain a pleasing flame pattern and efficient combustion. Incorrect log placement may cause carbon build-up; excess thermal stress on the log set and stove parts, reduced efficiency, and high

levels of carbon monoxide. If the log set does not set into the firebox exactly as outlined, contact your dealer for assistance.

## INSTALLATION OF THE LOG SET

(Refer to figures 11 & 12 for log set assembly)

1. Open the front door using a 5/32 allen wrench. Loosen the bolt that fastens the doorknob to the door. It also unfastens the door from the firebox by turning it counterclockwise. Be careful not to chip the enamel when loosening the bolt. Pull the door open by grabbing the top edge of the door frame.
2. Remove the packaging material around the log set assembly. Be careful not to damage the log set when unpacking.
3. Gently place the Main Log (1) in the firebox against the center of the back wall.
4. Gently place the Top Log (2) on top of the Main Log (1), inserting the posts into the holes in the bottom side of the Top Twig.
5. Spread evenly across the Ember Screens, one layer high, the 2 ounces of Charcoal Embers . You will not need to use all of the Charcoal Embers. Keep the rest to use in the future.
6. With a 5/32" allen wrench, use the bolt to fasten the door to the firebox. Make sure the door and knob are properly secured to the firebox before turning the unit on. Be careful not to chip the enamel when fastening the door.



**Figure II Log Set**

## REMOVAL OF LOG SET

**CAUTION:** The log set and charcoal embers retain heat and can be very hot! Allow 2 to 3 hours after pilot light is turned off before handling.

To remove the log set, follow the Installation of Log Set instructions in the reverse order.

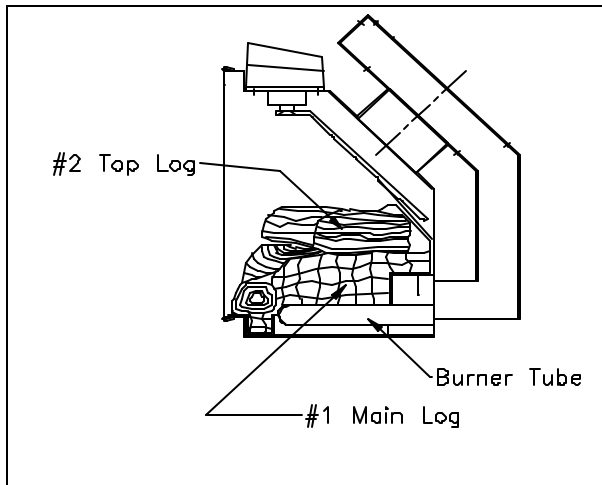

Figure 12: Log Set Assembly.

## LIGHTING THE UNIT FOR THE FIRST TIME

- › **WARNING:** If you do not follow these instructions exactly, a fire or explosion may result causing property damage, personal injury or loss of life.
- › **CAUTION:** Lighting the Tucson for the first time and adjustments to the unit should be performed by qualified service personnel.

### SMOKE AND FUMES WARNING

When lit for the first time, the Tucson will emit some smoke and fumes. This is normal “off-gassing” of the paints and oils used in

the manufacturing and assembly of the unit. Open windows to vent the room if necessary. The off gassing and fumes will subside after the first 10 to 20 minutes of operation.

### BREAK-IN WARNING

The natural stones used in the assembly of the Tucson were polished using a water-based polishing system prior to the assembly of the unit. Any residue moisture in the stones must be dried out slowly to avoid damaging the stones. This is accomplished by adhering to the following break-in procedure.

### BREAK-IN PROCEDURE

When lit the first time, the Tucson should be burned for no more than 15 minutes, then allowed to cool for 1 to 2 hours. This gentle warming and cooling of the unit will allow any residual moisture in the stones to evaporate slowly. Once this break-in procedure has been completed, the Tucson can be burned at will with no time restrictions on the length of burn.

### ODORS AND IMPURITIES

A heater of this type may produce odors during heater operation due to impurities that may exist in the immediate area. Sources of impurities can be cleaning solvents, paint solvents, cigarettes, smoke, pet hair, dust, adhesives, new carpet, and/or textiles. Such odors will dissipate. However, opening a window or otherwise providing additional ventilation to the area can alleviate the condition. If any odor persists, contact your dealer or an authorized service technician.

### PILOT LIGHT WARNING

The Tucson has a piezoelectric spark igniter (the push button located next to the gas control valve behind the valve access door), which ignites the pilot light by means of a

spark at the pilot light assembly. Do not attempt to light the unit with a match or by any means than the piezoelectric spark.

## PREPARE FOR LIGHTING

Prepare for the lighting procedure by adjusting the thermostat (if equipped) to its lowest setting or OFF position. If the gas control knob is not in the OFF position, turn the knob fully clockwise to OFF. Locate the variable output control knob and turn it fully clockwise to the highest setting.

Prior to lighting the unit for the first time, wait 5 minutes to allow any residual gas within the unit to dissipate. Smell all around the appliance area for gas. Be sure to smell next to the floor because some gases are heavier than air and will settle on the floor. If you do not smell gas after this five-minute period, proceed with the lighting procedure. If you do smell gas, **DO NOT** proceed with the lighting procedure. Instead, **immediately refer to the What To Do If You Smell Gas Warning, on the cover of this manual.**

**WARNING:** The valve control has an interlock device. After shutting off all gas flow, the pilot burner cannot be relit until the thermocouple has cooled, allowing the electromagnet to be released (approx. 60 seconds). The gas control knob is designed to be operated by hand. Do not use any tools during this operation. Damaged knobs may result in serious injury.

## INITIAL ADJUSTMENTS

Once the Tucson has been set in place, connected and assembled as described in the Clearances To Combustibles, Venting Components & Configurations, Electrical Connections, And Gas Supply and Connections sections of this manual, the unit is almost ready to be lit for the first time. The manufacturer tests each unit prior to shipment, so ignition should take place

without failure. However, a number of small adjustments may be necessary to compensate for variations in gas pressure, altitude, and other factors particular to each installation.

## VARIABLE OUTPUT CONTROL

The gas control valve is equipped with a variable output control. This control varies the rate of heat produced by the unit by varying the gas pressure to the main burner tube. A combination of heat output and the thermostat setting affect the length of the burn cycle. If your stove turns on and off too often, try, first, reducing the burn cycle by turning the HI/LOW knob, on the control valve, to a lower setting. Using the variable output control, the heat output of the unit can be reduced for mild fall and spring months, or maximized for the colder winter months. This adjustment can be made, by the homeowner, as necessary by turning the variable output control knob to “HI”, “LO” or any setting in between.

## LIGHTING INSTRUCTIONS

**NOTE:** The gas control knobs and the piezo ignitor are located behind the control valve access door, under the front of the unit.

1. STOP! Read the What To Do If You Smell Gas! Warning (on the cover of this manual).
2. Set the on/off/T’stat switch or thermostat to the “OFF” position.
3. Unplug the fan accessory, if so equipped.
4. Push in and turn gas control knob clockwise to “OFF”. *(If not previously lit, the knob should be in this position.)*
5. Wait (5) five minutes to clear out any gas. If you then smell gas, STOP! *Smell all around the appliance area for gas. Be sure to smell next to the floor because some gases are heavier than air and will settle on the floor. If you smell gas*

***immediately follow the What To Do If You Smell Gas! warning on the cover of this Manual.*** If you do not smell gas, proceed to the next step.

6. Turn gas control knob counter-clockwise to "PILOT".
7. Push in control knob all the way and hold in. Immediately light the pilot with the gas lighter (push in and "click" the piezoelectric spark ignitor button several times until lit). Continue to hold the control knob in for about 20 seconds after the pilot is lit. Release the knob and it will pop back out. Pilot should remain lit. If the pilot goes out, repeat the operation.
  - If knob does not pop out when released, stop, shut off the gas supply to the heater and immediately call a qualified service technician or gas supplier.
  - If the pilot will not stay lit after several tries, turn the gas control knob "OFF" and call a qualified service technician or gas supplier.
8. After the pilot lights, turn gas control knob counter-clockwise to "ON".
9. If the ON/OFF/T'stat switch is set to "ON", the stove should now be lit. If the thermostat (or remote) has been installed, set the ON/OFF/ T'stat switch to "T'stat" and turn the thermostat (or remote) to "ON". Then set the desired temperature.
10. Shut the gas control valve access door.
11. Plug in the fan accessory, if so equipped.
12. If T'stat was selected, set thermostat to "ON" and set desired temperature setting. Normally, if T'stat position was selected, the main burner is cycled on and off by the thermostat or the "on/off" switch located on the bottom of the thermostat body.

**NOTE:** When pressing/clicking the piezoelectric spark ignition button to light the pilot, watch through the glass (front) of the unit. Click the ignitor button until a flame is visible at the pilot. Once the pilot is lit, continue to press on the gas control knob for another 20 seconds, then release. Ascertain that the pilot is still lit by looking through the front door. If lit, then turn the gas control knob fully counter-clockwise to the "ON" position. If the pilot fails to light, or if it went out due to a premature release of the gas control knob while pressed in the "PILOT" position, wait 60 seconds for the Interlock to release. Then repeat the lighting process as described in this section of the manual.

Once the pilot has been lit, the gas control knob has been turned to the "ON" position, and the ON/OFF/T'stat switch has been turned to "ON", the main burners should light immediately. If you would like to use the thermostat and it has been installed, switch the ON/OFF/T'stat switch to thermostat. Turn the thermostat to "ON" and set it to a higher position so that it "calls" for heat in order to turn light the main burners (i.e. turns the unit on). Note that the thermostat controls the on/off cycling of the main burners, but the pilot remains lit regardless of the thermostat setting. The only way to turn the pilot off is to turn the gas control knob fully clockwise to the "OFF" position.

### **TO TURN OFF GAS TO APPLIANCE**

1. Set the thermostat to the "OFF" position or turn the ON/OFF/T-STAT switch to the "OFF" position.
2. If shutting the unit off for the non-heating season, turn the gas control knob fully clockwise to

the “OFF” position. Do not force the knob to turn.

### **PILOT ADJUSTMENT**

The pilot light is preset by the manufacturer and should not need adjustment. The pilot light flame should be large enough to engulf the thermopile and thermocouple located next to the pilot, but not so large as to create excessive noise or consume excessive gas. (Refer to figure 2 on page 10) However, it can be adjusted by means of the pilot light adjustment screw located on the gas control valve. Open the valve door to access the pilot adjustment screw. Note that the pilot flame must engulf the thermopile so that the thermopile can generate sufficient milli-voltage (325 to 500-mv) to power the milli-volt gas control valve.. Controlling the Tucson by the wall-mounted thermostat may become erratic, nonexistent, or the unit may go out, if the pilot flame is too small or misdirected away from the thermopile.

### **WARNING**

The control has an interlock device. If the stove has been lit, it will not relight immediately. After shutting off all gas flow, the pilot burner cannot be relit until the thermocouple has cooled, allowing the electromagnet to be released (*Approx. 60 sec.*). The gas control knob is designed to be operated by hand. Do not use any tools during this operation.

### **BURNER FLAME APPEARANCE**

Once the unit is lit, observe the flame pattern and adjust as necessary. Also, a periodic visual check of the burner flame should be performed. The burner flames can be adjusted by means of the air shutter. To determine if the burner flame needs adjustment, it is necessary to view the flame pattern with the variable output control knob at its highest setting (turn fully clockwise).

Allow the unit to operate for 10 minutes enabling the entire unit to reach temperature and for the flame pattern to stabilize. The flame pattern should be similar to the one shown in Figure 3. There are several guidelines to aid in determining if the flame pattern is correct:

1. The flame should not be dirty, smoky, sooty, or lick the top of the stove.
2. The flame should not rise off of the burner tube, called “lifting”.
3. Flames should not impinge heavily on the log set. They should “fit” through the pre-formed spaces designed in the log set.

### **AIR SHUTTER**

The air shutter is used to regulate the air-to-gas combustion mixture, which in turn influences the size and color of the flames. The air shutter has been positioned in the general location needed for the type of gas being used, however, if the unit is not burning as well as it should, then the air shutter may need adjusting. The air shutter may need adjustment once the unit has been installed to compensate for variations in supply line pressure, restriction plate position, altitude, gas type conversions, and other variables.

### **AIR SHUTTER ADJUSTMENTS**

The air shutter is adjustable while the stove is burning by loosening the adjusting nut located under the rear right hand corner of the stove. This nut is hot and should not be touched. Use only metal tools for this adjustment.

Moving the nut toward the front of the stove increases the air and moving the nut toward the back of the stove decreases the air. Tighten the nut after making adjustment. The air shutter is factory set and only a qualified gas technician should make adjustments.

**Note:** Very little movement is needed to substantially change the burn and flame patterns.

Some conditions cannot be corrected through air shutter adjustment; an adjustment must be made to the gas supply pressure. Supply line/manifold gas line pressure adjustments must be performed by qualified service personnel. Do not attempt to complete any part of the installation or adjustment of this unit unless technically qualified to do so.

To determine if the air shutter needs adjustment, it is necessary to view the flame pattern with the variable output control knob at its highest setting. Allow the unit to operate for 10 minutes to allow the entire unit to reach temperature and for the flame pattern to stabilize. Generally, the more air (open shutter) in the mixture, the bluer the flame. Less air (closed shutter) results in a more yellow flame, but too little air will

result in incomplete combustion, low efficiency and a dirty burn. There are two simple guidelines to aid in determining the correct flame pattern:

1. if the flame at the base of the logs is completely blue, the air shutter may be open too far;
2. if the flame is dirty or licks the top of the stove, the air shutter may be closed too far.

Some conditions cannot be corrected through air shutter adjustment; an adjustment must be made to the gas supply pressure or by changing the restriction plate location. Qualified service personnel must perform supply line/manifold gas line pressure adjustments and restrictor plate adjustments. Do not attempt to complete any part of the installation or adjustment of this unit unless technically qualified to do so.

## PARTS LISTS

<b>Part #</b>	<b>Description</b>	<b>Part #</b>	<b>Description</b>
1741-350	3-5/16" x 10-5/16"(84 x 262) Stone	5950-922	Restriction Plate
1741-351	7-1/2" x 6-1/2" (190.5 x 165) Stone	5710-596	Back Shroud
2310-850	HT Exc. Base	7210-103	Push Button Piezo Igniter
2310-860	HT Exc.	7211-430	Piezo Ceramic and Wire
2710-220	Ash Lip	7211-232	Burner Tube
2710-480	Exhaust Baffle	7211-310	Gas Valve SIT
2710-511	Front Door	93-56200	NG Conversion Kit
5710-170	Door Hinge Bracket	93-56201	LP Conversion Kit
5710-180	Door Latch Bracket	7200-240	Burner Orifice (NG) #40
2710-560	Glass Ret. Frame	7200-253	Burner Orifice (LP) #53
2710-581	Front Grill	7211-370	Pilot Burner Assembly
2710-810	Top Grill	7211-390	3 Way Pilot Hood and Clip
2710-321	Side. Right	7211-131	.30 Pilot Orifice (LP)
2710-326	Side, Left	7211-163	.62 Pilot Orifice
2710-655	Handle, Door	7211-470	Thermocouple
3030-027	Glass 13-1/4: x 1/8" x 5mm	7210-090	Thermopile
3110-057	3/8" Low Density Door Rope	7211-009	Pilot Tube
3160-080	3/4" Tape (glass)(FT)	7211-560	Main Log
3160-150	Gasket Firebox/Air Heat Exchanger	7211-561	Top Log
3160-075	5/8" x 1/4" Rope Gasket	7211-558	Charcoal Embers
3160-152	Pilot Gasket	97-57000	Blower Kit
3160-155	Gasket 4"	7000-015	Thermostat Wire 40'
3160-157	Gasket 6"	7200-506	Thermostat
5320-075	Ember Screen, Left	7000-200	3-Way On/Off Switch
5320-077	Ember Screen, Right	7211-231	Shutter, Air Slider
5710-121	Valve Bracket		
5710-128	Valve Door		
5320-072	Burner Tube Holder		
5710-598	Back Shroud Extension		
5710-470	Stone Clips		
5710-512	Firebox/Air Plenum		
5710-594	Exhaust Baffle Clip		

### › **WARNING:**

***Do not substitute Materials.*** For replacement parts, or for information about parts or service, contact your authorized HearthStone retailer. For the name of the authorized retailer nearest to you, call (802) 888-5232 or write:

HearthStone Quality Home Heating Products  
 317 Stafford Ave. Morrisville, Vermont 05661  
 E-Mail: [cservice@hearthstonestoves.com](mailto:cservice@hearthstonestoves.com)

**TROUBLESHOOTING**

<b>Symptom</b>	<b>Possible Cause</b>	<b>Corrective Action</b>
1. Pilot will not light.	<p>A. Insufficient gas pressure, air in the pilot line, or dirty or kinked gas line.</p> <p>B. Pilot orifice plugged.</p> <p>C. Defective or misaligned electrode at pilot.</p> <p>D. Defective ignitor.</p> <p>E. After sitting for "off" season (summer), pilot assembly may be dirty.</p>	<p>A. Using the piezo sparker, try to light the pilot. If it will not light, check the inlet gas pressure.</p> <p>B. Clean or replace the pilot assembly.</p> <p>C. If a match lights a pilot, check the electrode gap and location. Should be a 1/8" gap in the flame area.</p> <p>D. Check for a good connection between ignitor and electrode. Check wire insulation. If properly connected and no spark, replace ignitor.</p> <p>E. Clean or replace the pilot assembly.</p>
2. Pilot will not stay lit after carefully following lighting instructions.	<p>A. Low or too high gas pressure</p> <p>B. Faulty connections.</p> <p>C. Defective thermocouple.</p> <p>D. Pilot dirty or plugged.</p>	<p>A. Check for proper inlet pressure for the gas being used.</p> <p>B. Measure voltage between valve body and solder connection on the rear of the valve (where the blue wire connects). It should be no less than 7 mV.</p> <p>C1. Ensure that the thermocouple connection at the gas valve is tight.</p> <p>C2. Check thermocouple output using millivolt meter. Disconnect from valve and read voltage across wire ends. If the reading is less than 15 mV, replace the pilot assembly.</p> <p>C3. If burning NG, check pilot flame to see that it is impinging on the top of the thermocouple. Clean or replace pilot for maximum flame impingement.</p> <p>D. Clean or replace the pilot assembly.</p>

**TROUBLESHOOTING**

<b>Symptom</b>	<b>Possible Cause</b>	<b>Corrective Action</b>
3. Pilot burning, no gas to main burner, valve knob in the "ON" position, thermostat and/or on/off/t'stat switch in the "ON" position.	<p>A. Thermostat switch or wires defective.</p> <p>B. Thermopile may not be generating sufficient voltage.</p> <p>C. Plugged burner orifice.</p>	<p>A. Check thermostat/wiring for proper connections. Place jumper wire across terminals at thermostat. If burner comes on, replace defective thermostat. If not OK, place jumper across thermostat wires at gas valve. If burner comes on, tighten connections, or replace faulty wires.</p> <p>B. Check thermopile output, using a milli-volt meter. Take the readings across generator terminals of the gas valve. (TPTH and TP). Milli-volt reading should be greater than 325 mV. If not, replace the pilot assembly. If the meter reading is OK, but the burner does not come on, replace the gas valve.</p> <p>C. Remove and check burner orifice, clean or replace. Note: do not use any metal cleaning device, as this may damage the orifice.</p>
4. Pilot and burner come on, but go out after some warm-up.	<p>A. Inconsistent, or insufficient flame on thermopile.</p> <p>B. Insufficient gas pressure.</p>	<p>A. Adjust pilot flame size and assure that the flame is aimed directly at the thermopile.</p> <p>B. Check line pressure to ensure that the correct inlet pressure is present for the type of gas being used. If propane pressure is inconsistent, check for water condensation at the regulator.</p>
5. Frequent pilot outage problem.	A. Pilot flame may be too low or blowing, (high), causing the pilot safety to drop out.	A. Clean and/or adjust the pilot flame for maximum impingement on the thermopile and thermocouple.
6. Glass fogs	A. A normal result of gas combustion.	A. After the heater has warmed up, the glass should clear.
7. Blue Flames	A. A normal result during the first 20 minutes.	<p>A. Flames should begin to turn more yellowish after 20 minutes of burning.</p> <p>B. If the blue color stays; adjust the air shutter for a proper burn.</p>

**TROUBLESHOOTING**

<b>Symptom</b>	<b>Possible Cause</b>	<b>Corrective Action</b>
8. Floating flames, lazy ill-defined, quiet flames, which roll around, sometimes completely off of the port, sometimes with overly, yellow tips. Possible sooting. Usually accompanied by the odor of aldehydes.	<p>A. Potentially dangerous incomplete combustion due to incorrect air to fuel ratio (lack of combustion air or excessive fuel delivery I.e. excessive gas pressure, overrating of appliance).</p> <p>B. Incorrect air intake/exhaust flow system. Causes may be:</p> <p>B1. Blocked burner. B2. Blocked primary air B3. Blocked secondary air inlets</p>	<p>A. Check the appliance input rate and reduce if necessary. The air intake/exhaust flow system may be too restrictive or blocked (the rate at which the exhaust leaves [draft] determines the rate at which the combustion air is delivered). Poor draft results in insufficient air delivery or a restricted exhaust. Correct air intake/exhaust flow system.</p> <p>B1. Clear ports. B2. Clear obstructions. B3. Clear obstructions.</p> <p>C. If gas pressures are correct and the flames stay the same, adjust the air shutter for a proper burn.</p>
9. Burner flashback. Air-gas mixture ignites inside the burner near the orifice, usually creating a roaring noise like a blowtorch. The problem is an imbalance of gas flow velocity and burning speed pattern.	<p>A. Excessive primary air.</p> <p>B. Burner input underrated.</p> <p>C. Valve leak if flashback occurs with burner valve in off position.</p> <p>D. Improper gas pipe size.</p>	<p>A. Adjust the air shutter for a proper burn.</p> <p>B. Check input rate. Check input pressure using a manometer. Confirm correct gas pressure at house meter or tank (call gas company). Confirm burner orifice size.</p> <p>C. Replace valve. If above corrections do not eliminate flashback, replace burner.</p> <p>D. Correct plumbing.</p>
10. Delayed ignition (makes a sudden "whoosh" noise as the burner lights). This is a buildup of gas prior to ignition. This is more prevalent with propane (LP) fuel.	<p>A. Incorrect air-to-fuel ratio.</p> <p>A1. Primary air incorrect. A2. Burner ports plugged.</p> <p>B. Improper log placement.</p>	<p>A1. Adjust the air shutter for a proper burn.</p> <p>A2. Open ports to allow for proper travel of flames.</p> <p>B. Reposition logs to eliminate interference with flame travel.</p>

## HEARTHSTONE GAS-FIRED STOVE AND INSERT LIMITED WARRANTIES

**These warranties give you specific legal rights. You may also have other rights which vary from State to State.**

HearthStone Quality Home Heating Products, Inc. (HearthStone) warrants **to the original purchaser only** (the “Original Purchaser”) the new gas-fired stove/insert manufactured by HearthStone and purchased by the Original Purchaser (referred to as the “Stove” for simplicity) against any of the occurrences listed in this document that result from defects in material or workmanship. All obligations of HearthStone under this document commence on the date the Original Purchaser purchases the Stove (the “Purchase Date”).

### **LIMITED LIFETIME WARRANTY**

HearthStone warrants the following parts of the Stove against the following occurrences that result from defects in material and workmanship:

- All cast iron parts, including the cast iron heat exchanger – against breakage, cracking or burn-through.
- All stones – against cracking or breakage due to thermal stress, **excluding** surface and hairline cracks and scratches that do not affect the operation or safety of the Stove.
- Glass – against breakage due to thermal shock.

### **LIMITED FIVE-YEAR WARRANTY**

HearthStone warrants the following parts of the Stove against the following occurrences that result from defects in material and workmanship:

- Firebox and firebox baffle – against breakage, cracking or burn-through.
- Convective heat exchanger – against breakage, cracking or burn-through.
- Burners, air shutters and orifices – against breakage, cracking or burn-through.
- Ceramic logs and embers – against breakage, cracking or burn-through.

**This warranty expires on the fifth (5<sup>th</sup>) anniversary of the Purchase Date.**

### **LIMITED THREE-YEAR WARRANTY**

HearthStone warrants the following parts of the Stove against the following occurrences that result from defects in material and workmanship:

- Gas train, including gas valve, millivolt wiring, spill switch, pilot assembly, thermopile, thermocouple, piezo igniter, and, if the Stove is a vent-free model, ODS system – against breakage or malfunction.

**This warranty expires on the third (3<sup>rd</sup>) anniversary of the Purchase Date.**

### **LIMITED ONE-YEAR WARRANTY**

HearthStone warrants the following parts of the Stove against the following occurrences that result from defects in material and workmanship:

- Enamel Finish – against peeling or fading, **excluding** chipping, mechanical abrasion, chemical abrasion or crazing.
- Gaskets and sealants – against breakage or deterioration.
- Accessories and electrical components such as blowers, switches and thermo discs, **excluding** venting components, hearth components, electrical components and other components or accessories used in conjunction with the installation of the Stove **not** manufactured or supplied by HearthStone – against breakage or malfunction.

**This warranty expires on the first (1<sup>st</sup>) anniversary of the Purchase Date.**

### **EXCLUSIONS**

The warranties contained in this document do not cover, nor is HearthStone responsible for:

1. Damage resulting from installation or operation of the Stove in a manner contrary to the owner's manual.
2. Damage or non-performance resulting from faulty or incomplete setup, installation and start-up or mishandling, abuse, or misuse of the Stove, including but not limited to over-firing.
3. Damage resulting from installation, modification, alteration, repair or service of the Stove by any party other than HearthStone or an authorized HearthStone dealer (a "Dealer").
4. Damage due to water or due to installation of the Stove in a damp or high condensation area.
5. Damage due to installation of the Stove in an atmosphere contaminated by damaging chemicals, including but not limited to chlorine, fluorine or salts.
6. Scratches on glass, enameled surfaces or stones due to mechanical abrasion.
7. Standard wear and tear of the Stove resulting from normal usage over time.
8. Damage, operational-related problems, or inadequate performance caused by site, installation or environmental conditions beyond HearthStone's control, including but not limited to nearby trees, rooftops, buildings, wind, hills, mountains, inadequate or excessive venting, insufficient make up air, or negative air pressure whether or not caused by mechanical systems such as furnaces, exhaust fans, clothes dryers, etc.
9. A defect in any part of the Stove if the Original Purchaser fails to comply with HearthStone's or a Dealer's request to ship the part or the Stove to HearthStone or a Dealer, as the case may be.

THE WARRANTIES CONTAINED IN THIS DOCUMENT ARE EXCLUSIVE AND ARE GIVEN BY HEARTHSTONE AND ACCEPTED BY THE ORIGINAL PURCHASER IN LIEU OF ALL OTHER EXPRESS WARRANTIES AND ANY OBLIGATIONS, LIABILITIES, RIGHTS, CLAIMS, OR REMEDIES IN CONTRACT OR TORT, WHETHER OR NOT ARISING FROM HEARTHSTONE'S NEGLIGENCE, ACTUAL OR IMPUTED. ALL IMPLIED WARRANTIES, INCLUDING THE WARRANTIES OF MERCHANTABILITY AND FITNESS FOR A PARTICULAR PURPOSE, ARE GIVEN **ONLY** TO THE EXTENT REQUIRED BY FEDERAL OR STATE LAW. EXCEPT AS OTHERWISE REQUIRED BY STATE LAW, UPON THE EXPIRATION OF THE EXPRESS LIMITED WARRANTIES CONTAINED HEREIN, **NO** IMPLIED WARRANTIES, INCLUDING THE IMPLIED WARRANTIES OF MERCHANTABILITY OR FITNESS FOR A PARTICULAR PURPOSE, SHALL APPLY TO THE SUBJECT STOVE. **SOME STATES DO NOT ALLOW LIMITATIONS ON HOW LONG AN IMPLIED WARRANTY LASTS, SO THE ABOVE LIMITATION MAY NOT APPLY TO YOU.**

THE WARRANTIES CONTAINED IN THIS DOCUMENT EXTEND **ONLY** TO THE ORIGINAL PURCHASER OF THE STOVE WARRANTED HEREUNDER. THEY DO NOT EXTEND TO ANY SUBSEQUENT OWNERS.

UNDER NO CIRCUMSTANCES SHALL HEARTHSTONE BE LIABLE TO THE ORIGINAL PURCHASER OR ANY OTHER PERSON FOR ANY INCIDENTAL OR CONSEQUENTIAL DAMAGES, INCLUDING BUT NOT LIMITED TO DAMAGE TO PROPERTY OR PERSONAL INJURIES, WHETHER ARISING OUT OF BREACH OF WARRANTY, TORT, OR OTHERWISE, EVEN IF HEARTHSTONE HAS BEEN APPRAISED OF THE POSSIBILITY OF SUCH DAMAGES. **SOME STATES DO NOT ALLOW THE EXCLUSION OR LIMITATION OF INCIDENTAL OR CONSEQUENTIAL DAMAGES, SO THE ABOVE LIMITATION OR EXCLUSION MAY NOT APPLY TO YOU.**

## **QUALIFYING FOR WARRANTY COVERAGE**

To obtain performance of any obligation under this document, the Original Purchaser must, **within the applicable warranty time period**, contact HearthStone, at the address listed in the Warranty Registration section below or at **(802) 888-5235**, or a Dealer for instructions regarding the return of defective parts for repair, the return of the Woodstove for repair, or a Dealer service call. The Original Purchaser should refer to the Dealer network search engine contained on HearthStone's Web site ([www.hearthstonestoves.com](http://www.hearthstonestoves.com)), or call HearthStone at (802) 888-5235, to find a Dealer nearest the Original Purchaser's location.

## **REMEDY**

The remedy for any breach of the foregoing warranties will consist of repair or replacement, at HearthStone's option, of any covered defect in the Stove. When the Original Purchaser contacts HearthStone or a Dealer, HearthStone or the Dealer, as the case may be, will instruct the Original Purchaser to **either** return the defective part, or the entire Stove (if needed), with shipping prepaid, to HearthStone or a Dealer **or** allow a Dealer to make a service call at the place where the Stove is located. In the event the Original Purchaser refuses to allow a Dealer to make a service call, HearthStone or a Dealer, as the case may be, will request that the Original Owner return the defective part, or the entire Stove (if needed), with shipping prepaid, to HearthStone or a Dealer.

**Notwithstanding any other provision of this document, the Original Purchaser shall pay for any travel fees and service charges related to a Dealer's service call.**

**Parts:** HearthStone will replace defective parts covered by the foregoing warranties at no charge.

**Labor:** Within the first (1<sup>st</sup>) year after the Purchase Date, HearthStone will pay for warranty labor performed by a Dealer at HearthStone's published labor rates in effect at the time the labor is performed. Thereafter, the Original Purchaser is responsible for the cost of labor.

**Shipping cost for parts:** Within the first ninety (90) days after the Purchase Date, HearthStone will pay for the shipping of Stove parts covered by any of the foregoing warranties to and from HearthStone or a Dealer, as the case may be. Thereafter, the Original Purchaser is responsible for all shipping costs related to shipping Stove parts to and from HearthStone or a Dealer, as the case may be.

**Shipping cost for the Stove:** Within the first (1<sup>st</sup>) year after the Purchase Date, if the Original Purchaser is instructed to return the Stove to HearthStone or a Dealer for repair, HearthStone will pay fifty percent (50%) and the Original Purchaser will pay fifty percent (50%) of the **shipping** costs related to shipping the Stove to and from HearthStone or a Dealer, as the case may be. Thereafter, the Original Purchaser is responsible for one hundred percent (100%) of all of the shipping costs related to shipping the Stove to and from HearthStone or a Dealer, as the case may be. Notwithstanding any other provision of this document, in no event will HearthStone pay for any Dealer fees or other fees for pick up or delivery of the Stove returned for repair; the Original Purchaser shall be responsible for any such fees.

## **WARRANTY REGISTRATION**

The Original Purchaser may send a completed and signed Warranty Registration Form, which is enclosed in the Stove warranty packet, to the following address:

**HearthStone Quality Home Heating Products, Inc.**  
Warranty Department  
317 Stafford Avenue  
Morrisville, VT 05661

**NOTE: SENDING IN THE SIGNED WARRANTY REGISTRATION FORM IS NOT A CONDITION OF WARRANTY COVERAGE OR HEARTHSTONE'S PERFORMANCE.**