

Owner's Manual & Installation Guide for the  
**Tudor** (8120) GAS-FIRED DIRECT-VENT HEATER



**READ THIS OWNER'S MANUAL** - Operate and maintain this gas heater according to this instruction manual.

**WARNING:** If the information in these instructions is not followed exactly, a fire or explosion may result causing property damage, personal injury or loss of life.

Do not store or use gasoline or other flammable vapors and liquids near this or any other gas appliance.

**WHAT TO DO IF YOU SMELL GAS:**

- Do not try to light any appliance.
- Do not touch electrical switches; do not use the phone in your building.
- Immediately call your gas supplier from a neighbors phone. Follow your gas supplier's instructions.
- If you cannot reach your gas supplier, call the fire department.

A qualified installer, service agency or gas supplier must perform installation and service. In the Commonwealth of Massachusetts, all installation of gas lines and gas fitting shall only be done by a licensed gas fitter or licensed plumber.

**AVERTISSEMENT:** Assurez-vous de bien suivre les instructions donné dans cette notice pour réduire au minimum le risque d'incendie ou pour éviter tout dommage matériel, toute blessure ou la mort.

Ne pas entresposer ni utiliser d'essence ni d'autre vaperurs ou liquides inflammables dans le voisinage de cet appareil ou de tout autre appareil.

**QUE FAIRE SI VOUS SENTEZ UNE ODEUR DE GAZ:**

- Ne pas tenter d'allumer d'appareil.
- Ne touchez à aucun interrupteur. Ne pas vous servir des téléphones se trouvant dans le batiment où vous vous trouvez.
- Appelez immédiatement votre fournisseur de gaz depuis un voisin. Suivez les instructions du fournisseur.
- Si vous ne pouvez rejoindre le fournisseur de gaz, appelez le service dos incendies.

L'installation et service doit être exécuté par un qualifié installer, agence de service ou le fournisseur de gaz.

HearthStone Quality Home Heating Products, Inc.  
317 Stafford Avenue,  
Morrisville, Vermont 05661-8695  
E-Mail: Info@hearthstonestoves.com



06-28-05

### INFORMATION SHEET

Use this page to record all relevant information concerning the purchase, installation, and maintenance of your Tudor Gas-Fired Direct-Vent heater. This information will facilitate servicing, purchase of replacement parts, and warranty claims (if necessary). Keep your original receipt in a safe place as proof of purchase.

Serial Number: \_\_\_\_\_

**Fuel type** (check one) \_\_\_\_\_ Natural Gas \_\_\_\_\_ Liquid Propane

**Sold by:** \_\_\_\_\_

Phone: \_\_\_\_\_ Date of Purchase: \_\_\_\_\_

**Installed by:** \_\_\_\_\_

Phone: \_\_\_\_\_ Date of Installation: \_\_\_\_\_

**Gas Supplier:** \_\_\_\_\_

Phone: \_\_\_\_\_

**Read this Owner's Manual** before installing or operating the Tudor. Retain this manual for future reference.

### SERVICE RECORD

**Important - Verify proper operation after servicing!**

Date	Who Performed Work	Work Performed	Notes:

<b>WHAT</b> Firebox Cleaning.....	<b>WHEN</b> annually	<b>WHAT</b> Door Gasket.....	<b>WHEN</b> Replacement as needed
Glass Cleaning.....	as needed		

## TABLE OF CONTENTS

INTRODUCTION.....	3
SPECIFICATIONS: .....	5
OWNER’S INFORMATION .....	6
INSTALLER’S INFORMATION .....	7
ITEMS REQUIRED FOR INSTALLATION.....	7
UNPACKING AND INSPECTION .....	7
CLEARANCE TO COMBUSTIBLES.....	8
VENTING INFORMATION .....	11
ELECTRICAL CONNECTIONS .....	17
GAS SUPPLY & CONNECTIONS .....	19
LOG PLACEMENT.....	20
INITIAL ADJUSTMENTS .....	23
ROUTINE MAINTENANCE AND CARE .....	27
PARTS LISTS.....	29
LIMITED WARRANTIES.....	34

## INTRODUCTION

Congratulations on your purchase of HearthStone’s Tudor Gas-Fired Direct Vent heater. The Tudor incorporates the latest in balanced vent gas technology, which will provide you with clean, efficient heat for years to come. Combustion air comes directly from the outside of your home to the sealed firebox system, eliminating the potential for annoying back drafts or other problems associated with home depressurization.

The Tudor will provide you with years of practical and convenient service. However, as with any gas appliance, the unit must be properly and safely installed and maintained by qualified service personnel to ensure safe and trouble-free operation. It includes the new TEK Firelog technology, which is an

amazing blend of realistic flames and glowing embers with incredible heating characteristics.

### READ THIS OWNER’S MANUAL

Operate and maintain this gas heater according to the instructions in this manual. For your safety, and years of trouble free operation, read this manual in its entirety. By following a few simple safety precautions and by performing minimal maintenance, the unit will remain appealing while providing years of quality performance.

### WARNING!

**A qualified service technician should do installation, and repair. A qualified service technician must inspect the appliance before use, and at least annually. More frequent cleaning may be required due to excessive lint from carpeting, bedding material, pets, etc. It is imperative that the control compartments, burners, and circulating air passages of the appliance are kept clean and free of obstructions. (*S’assurer que le brûleur et le compartiment des commandes sont propres. Voir les instructions d’installation et d’utilisation qui accompagnent l’appareil.*)**

**WARNING:** Do not operate this appliance with the glass, or any panel removed, cracked, or broken. Do not subject the door to abuse, such as striking or slamming shut. Replacement of the glass panel should be done by a licensed or qualified service person.

### NEVER BURN PAPER, WOOD OR OTHER MATERIALS

This gas heater is designed to burn natural gas or liquid propane (LP). Never burn any fuel not intended for use with this unit.

**HOT SURFACES**

Certain exposed surfaces of the Tudor will reach high temperatures during normal operation. Clearances to combustibles must be maintained, as specified in the “Clearances To Combustibles” section of this manual.

**Do not** use this appliance if any part has been under water. Immediately call a qualified service technician to inspect the heater and to replace any part of the control system and gas control that has been under water. *(Ne pas se servir de cet appareil s’il a été plongé dans l’eau, complètement ou en partie. Appeler un technicien qualifié pour inspecter l’appareil et remplacer toute partie du système de contrôle et toute commande qui ont été plongés dans l’eau.)*

**WARNING**

This gas appliance must not be connected to a chimney flue serving a separate solid-fuel burning appliance. NEVER VENT THE GAS HEATER TO OTHER ROOMS OR BUILDINGS. Masonry Conversions Kits are an acceptable venting option.

**Due to high temperatures the appliance should be located out of traffic and away**

**from furniture, draperies, clothing and flammable materials. Children and adults should be alerted to the hazards of high surface temperatures and should stay away to avoid burns to skin or clothing ignition. Young children should be carefully supervised when in the same room as the appliance. Clothing or other flammable material should not be placed on or near the appliance. (Surveillance les enfants. Garder les vêtements, les meubles, l’essence ou autres liquides à vapeur inflammables lin de l’appareil.)**

**FIRE HAZARD**

Do not store or use gasoline or other flammable vapors or liquids in the vicinity of this appliance. The Tudor should be located out of traffic and away from furniture, draperies, clothing, and flammable material.

**Any shield, door, or safety screen component removed for servicing will be replaced prior to operating the unit.**

**Certified for use by:**

Board of State Examiners of Plumbers and Gasfitters  
100 Cambridge Street, Room 1511  
Boston, Massachusetts 02202

## SPECIFICATIONS:

**LISTED AS:** Gas-Fired Direct-Vent Fireplace Heater

**Model:** Tudor Direct-Vent Gas Fireplace Heater (8120)

**Testing Agency:** OMNI-Test Laboratories, Inc.

**Tested to:** ANSI Z21.88-B 2003, CSA 2.33-M02, CAN/CGA2.17-M91  
Certified for Canada, CSA P.4.1

Approved for Mobile Home Installation

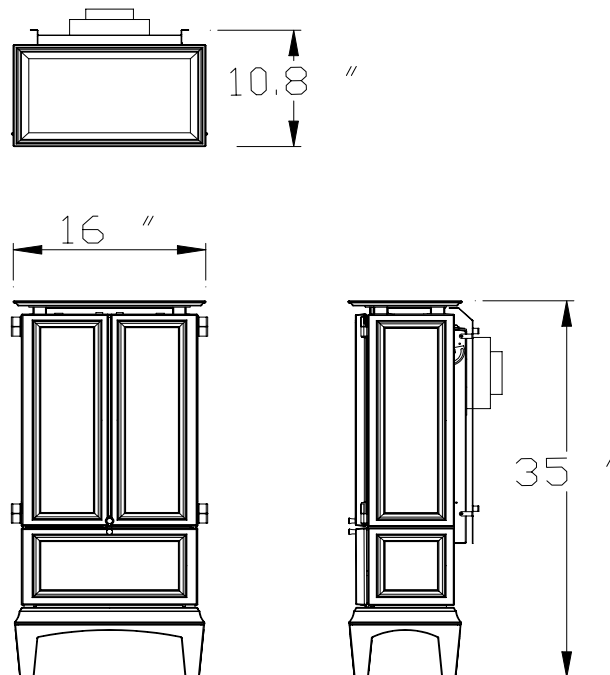

**Figure 1 Tudor Dimensions**

FUEL TYPE:	NG	LP
INPUT RATING (Btu/hr) 0-2000 ft	11,500	11,200
ORIFICE SIZE (DMS) 0-2000 ft	53	63
MANIFOLD PRESSURE - LO SETTING (in. W.c./kpa)	1.6/0.42	6.4/1.59
MANIFOLD PRESSURE - HI SETTING (in. W.c./kpa)	3.5/1.15	10.0/2.48
INLET PRESSURE - LO (in.w.c./kpa)	5.0/1.24	11.0/2.88
MINIMUM INPUT RATING (btu/hr)	7000	8500
MAXIMUM OUTPUT (btu/hr) 0-2000 ft	7652	7494

## OWNER'S INFORMATION

The installation must conform with local codes or, in the absence of local codes, the current National Fuel Gas Code, ANSI Z223.1 (NFPA 54) or CAN/CGA B149 Installation Code. (*Installer l'appareil selon les codes ou règlements locaux, ou, en l'absence de tels règlements, selon les Codes d'installation CAN/CGA-B149.*) **Do not use this appliance if any part has been under water. Immediately call a qualified service technician to inspect the heater and to replace any part of the control system and gas control that has been under water.** (Ne pas se servir de cet appareil s'il a été plongé dans l'eau, complètement ou en partie. Appeler un technicien qualifié pour inspecter l'appareil et remplacer toute partie du système de contrôle et toute commande qui ont été plongés dans l'eau.)

## DAILY OPERATION

The Tudor is easily operated by the homeowner once installed and adjusted by qualified service personnel. The unit can be controlled via the wall-mounted thermostat during the heating season. Set the thermostat to the desired room temperature and the unit will cycle on and off as required. By adjusting the variable output control located on the gas control valve, the rate of heat output can be varied to meet the heating requirements of the season. Choosing a low flame setting will result in longer burn cycles at a reduced output, while choosing a high flame setting will result in a shorter, hotter burn cycle. Through trial and error, the homeowner can select the optimum flame size for their setting and application.

During the summer non-heating season, switch the wall thermostat to "OFF", and turn off the pilot. This will improve the overall efficiency of the unit as the heat from the pilot is wasted. When putting the

unit back into service, follow the lighting instructions described on page 24.

When the unit is first lit, especially when cool, it is normal to experience some condensation on the inside of the window glass. This condensation will burn off within the first few minutes of operation. If continuous condensation on the window glass or dripping water from any part of the unit or venting system (chimney) is noted, immediately discontinue operation of the unit and contact qualified service personnel.

Clean the area around, under, and behind the unit on a regular basis to prevent the accumulation of dust and lint.

The Tudor requires minimal routine maintenance and care. It should always be cool and off when being cleaned, or serviced. Once a year, the unit, and venting system should be inspected by qualified service personnel to insure that they are clean, free of obstruction, safe, and in good working order. If service or maintenance is required, qualified service personnel should perform it.

## SERVICE CAUTION

If you believe your Tudor is not, in any way, performing properly, immediately discontinue operation until the unit has been inspected and approved by qualified service personnel. Prior to servicing the unit, turn the valve control knob clockwise to "OFF". The unit should be cool prior to servicing and cleaning. Use of any components not supplied by HearthStone on the stove voids all warranties. **Do not substitute components.**

## INSTALLER'S INFORMATION

### CODES

Adhere to all **local codes** or, in their absence, the latest edition of THE NATIONAL FUEL GAS CODE ANSI Z223.1 (NFPA 54) or CAN/CGA B149 Installation Code that can be obtained from:

**AMERICAN NATIONAL STANDARDS  
INSTITUTE, INC.**

1430 BROADWAY  
NEW YORK, NY 10018

OR

**NATIONAL FIRE PROTECTION  
ASSOCIATION, INC.**

BATTERY MARCH PARK  
QUINCY, MA 02269

A manufactured home (mobile) OEM installation must conform with the Manufactured Home Construction and Safety Standard, Title 24 CFR, Part 3280 (U.S.) or Standard for Manufactured Home Installation, ANSI/NCBCS A225.1 or Standard for Gas Equipped Recreational Vehicles and mobile Housing, CSA Z240.4.CAN/SCA Z240 MH (Canada). (*Installer l'appareil selon les codes ou règlements locaux, ou, en l'absence de tels règlements, selon les Codes d'installation CAN/CGA-B149.*)

### ITEMS REQUIRED FOR INSTALLATION

- \* External regulator (for propane/L.P.G. only)
- \* Piping which complies with local codes
- \* Pipe sealant approved for use with propane/L.P.G. (resistant to sulfur compounds)
- \* Manual shutoff valve
- \* Sediment trap (see page 18)
- \* Tee joint
- \* Pipe wrench
- \* Phillips head screwdriver
- \* 7/16-inch wrench
- \* Other parts as required by local code
- \* Safety Glasses
- \* Gloves

### PACKING LIST

- 1-Tudor Gas-Fired Heater
- 1-TEK Burner
- 2-Decorative TEK Firelogs
- 1-Tudor top casting
- 1-Owner's Manual
- 1-Thermostat
- 1-40' Thermostat wire
- 1-Wall thimble Insulation Blanket
- 1-Warranty Validation Form

Note: Vent kits and components are supplied separately. Failure to use the venting components specified by HearthStone QHHP, Inc. will void your warranty and could risk a fire.

### UNPACKING AND INSPECTION

#### Unpack and Inspect for Damage

The Tudor is packaged by the manufacturer to withstand shipment without damage. However, damage can still occur during transit; so take care to inspect for damage when unpacking and installing the unit. If any damage, or missing parts are detected, immediately contact your dealer.

**Do not install, or put into service, a damaged or incomplete heater.**

**The Tudor requires a pilot shield. This shield is shipped with the unit. Make sure the sure the shield is installed over the pilot with the open end is to the right (when you are facing the front of the stove)**

Inspect the Tudor for visible or concealed damage. The unit should appear to be square and true. The sheet metal parts should be smooth and free of bends and dents. The enameled cast iron should be free of chips or cracks. If visible or concealed damage is

found or suspected, contact your dealer for instructions.

With the accessory box removed and set aside, take care not to mar or chip the enameled legs, if applicable. Have someone help lift the stove out of the shipping box and set it into place.

The TEK Burner and TEK Firelogs supplied with the Tudor are contained in the accessory box. Always use great care when handling the decorative fire logs, as they are fragile and subject to damage and breakage if handled roughly. If a broken log is encountered, contact your dealer for replacement logs. Otherwise, set the logs aside until called for during the installation.

## INSTALLING THE TUDOR

**A complete Tudor REQUIRES the purchase of one of the following panel kits;**

91-8220010	Curio Matte (cast iron)
91-8220020	Curio Brown
91-8220059	Curio Blue/black
91-8220310	Keepsake Matte (grill + cast)
91-8220320	Keepsake Brown
91-8220359	Keepsake Blue/black
91-8220641	Heirloom Polished (stone)
91-8220653	Heirloom Brown
91-68200	Tile Insulation kit ( <b>Must be used with self purchased tiles</b> ) Do not paint, plaster or finish the tiles in any way. This may risk off gassing or a fire.

## HEARTH REQUIREMENT/FLOOR PROTECTION

The Tudor may be placed on any surface or wood floor, carpeting, or vinyl tile, with or

without legs. Installations must meet local codes.

### Removing the Tudor's legs

The Tudor has the unique possibility of having its legs removed, allowing for the unit to rest on its base. To do this, simply use two 7/16" wrenches or ratchets and loosen and remove the two centermost ¼-20 bolts and nuts holding the legs on. These can be reached the easiest from behind the unit and should be removed prior to any other connections have been made. Once removed, lift the unit off the legs and set in the desired location.

## CLEARANCE TO COMBUSTIBLES

Due to high surface temperatures, the unit should be located out of traffic and away from furniture and draperies. Clothing and other flammable material should not be placed on or near the heater. When positioning the unit always maintain adequate clearances around air openings into the combustion chamber and allow for adequate ventilation. Minimum clearances to combustibles must be maintained as shown in the illustrations of the *Clearances To Combustibles* section.

Be sure to consider the need for access to the gas control valve access door on the front of the unit as well as full access for periodic cleaning and servicing.

**Caution:** These clearances represent *minimum* distances in all cases, which, through testing in an independent laboratory to ANSI and CSA standards, will prevent fire or spontaneous combustion. We do not control the combustible materials exposed to heat by this product; therefore, an assessment must be made by the installer to prevent consequential damage of walls and flooring.

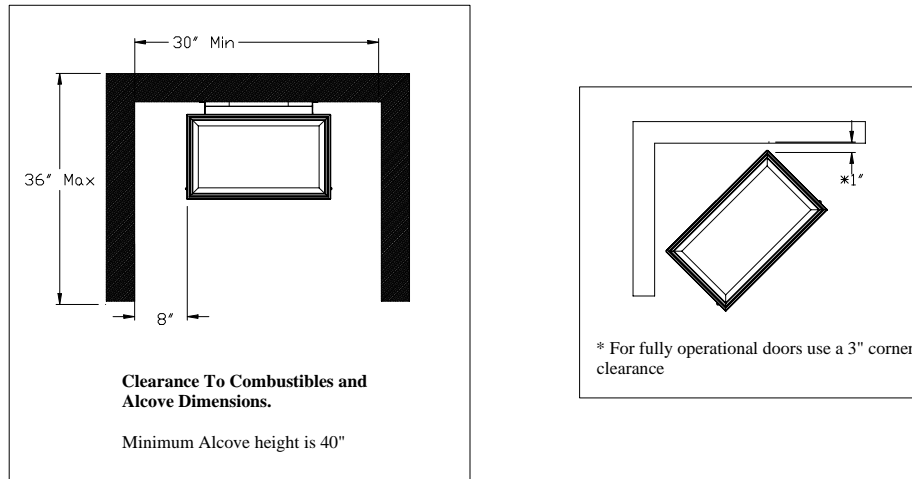

**Figure 2 Clearance to combustibles**

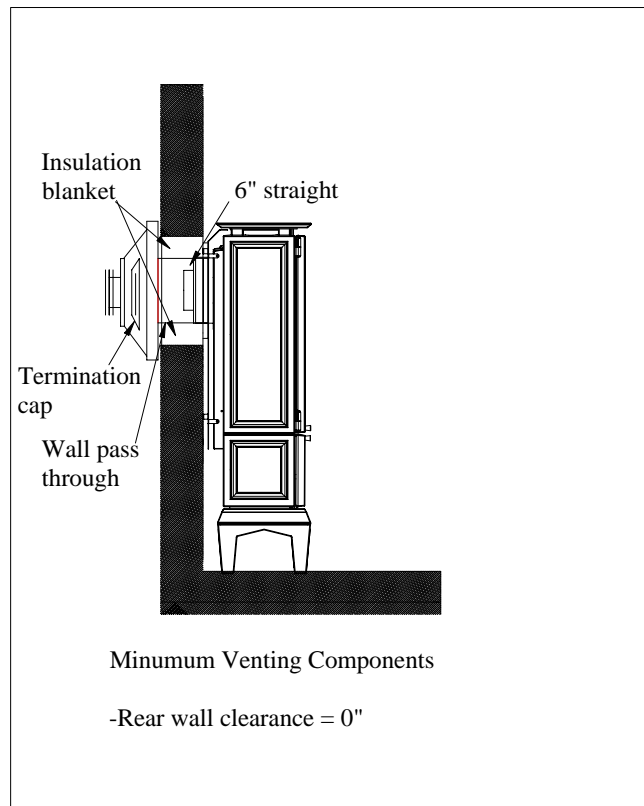

**Figure 3 Minimum vent clearances**

Acceptable Direct-Vent TERMINATION Cap locations.

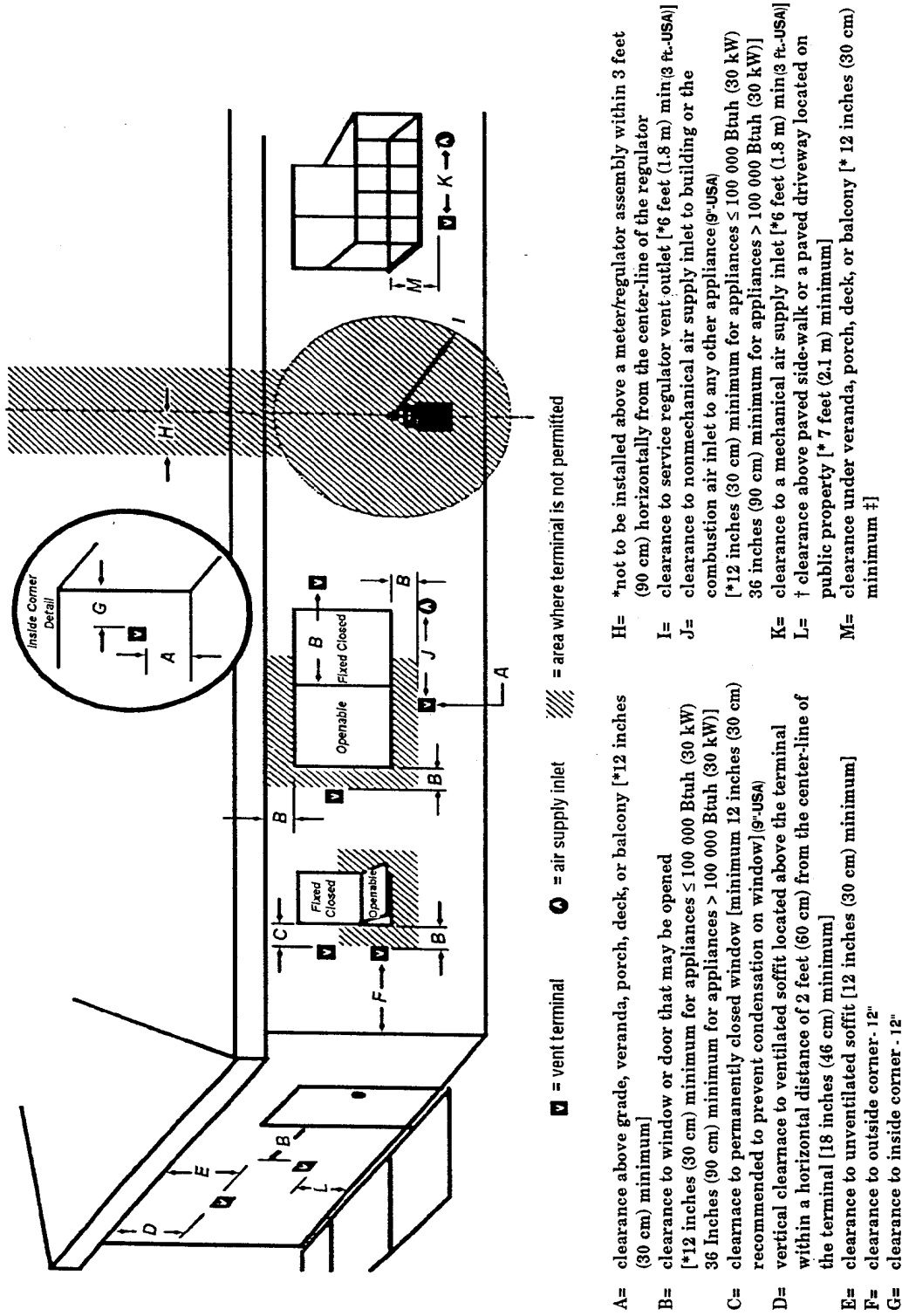

Figure 4 Termination clearances

† a vent shall not terminate directly above a side-walk or paved driveway which is located between two single family dwellings and serves both dwellings\*

‡ only permitted if verand, porch, deck, or balcony, is fully open on a minimum of 2 sides beneath the floor\*

\* as specified in CGA B149 Installation Codes Note: local Codes or Regulations may require different clearances

## VENTING INFORMATION

### VENT CONNECTION

1. An insulation blanket has been provided and must be added to any wall pass through (thimble) kit. This blanket is installed inside the wall pass through thimble and wraps around the pipe that protrudes through the wall. (*see figure 5*) The blanket must extend the full-length, front to back of the thimble.
2. The Tudor Direct Vent is approved for installation only with the vent connecting components listed; Simpson Dura-Vent Direct Vent GS, AmeriVent Direct, Selkirk Direct Temp™ or Secure Vent systems. Use the following instructions along with the pipe manufacturer's instructions to complete the installation.
3. Install the vent system according to the manufacturer's instructions.

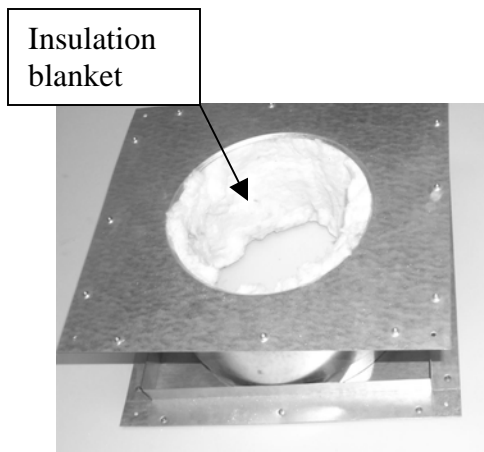

Figure 5 Wall thimble with insulation blanket

### RESTRICTION PLATE

There is a vent restriction plate that adjusts the flow rate of exhaust gases. This insures proper flames and efficiency for the wide variety of vent configurations. Controlling the draft also changes the aesthetics of the flame. The restriction plate consists of a rotating shutter behind the starter section of pipe and an adjustment plate with an index hole used to hold the shutter in a fixed position. The restriction plate has unlimited settings. Depending on the vent configuration, you may be required to adjust the restriction plate position. **For straight out the back installations no adjustment to the restrictor is necessary.**

### ADJUSTMENT TO RESTRICTION PLATE

Make sure the unit is cool before touching any part of the firebox. To adjust your restrictor for maximum flame appearance, loosen the Phillips head screw, found on the upper rear right side of the stove. Spin the indicator tab into the desired position. Rotating counterclockwise closes the exhaust gasses, while rotating clockwise opens the exhaust gases. Once the desired restriction is reached, tighten the screw. (*Refer to figure 6*) There are unlimited positions for the restriction plate, one (1) being the lowest and three (3) being the highest. (*Refer to Venting Configuration – Figure 6 for recommended restriction plate positions*)

NOTE: These positions are based on lab results and can have some variance.

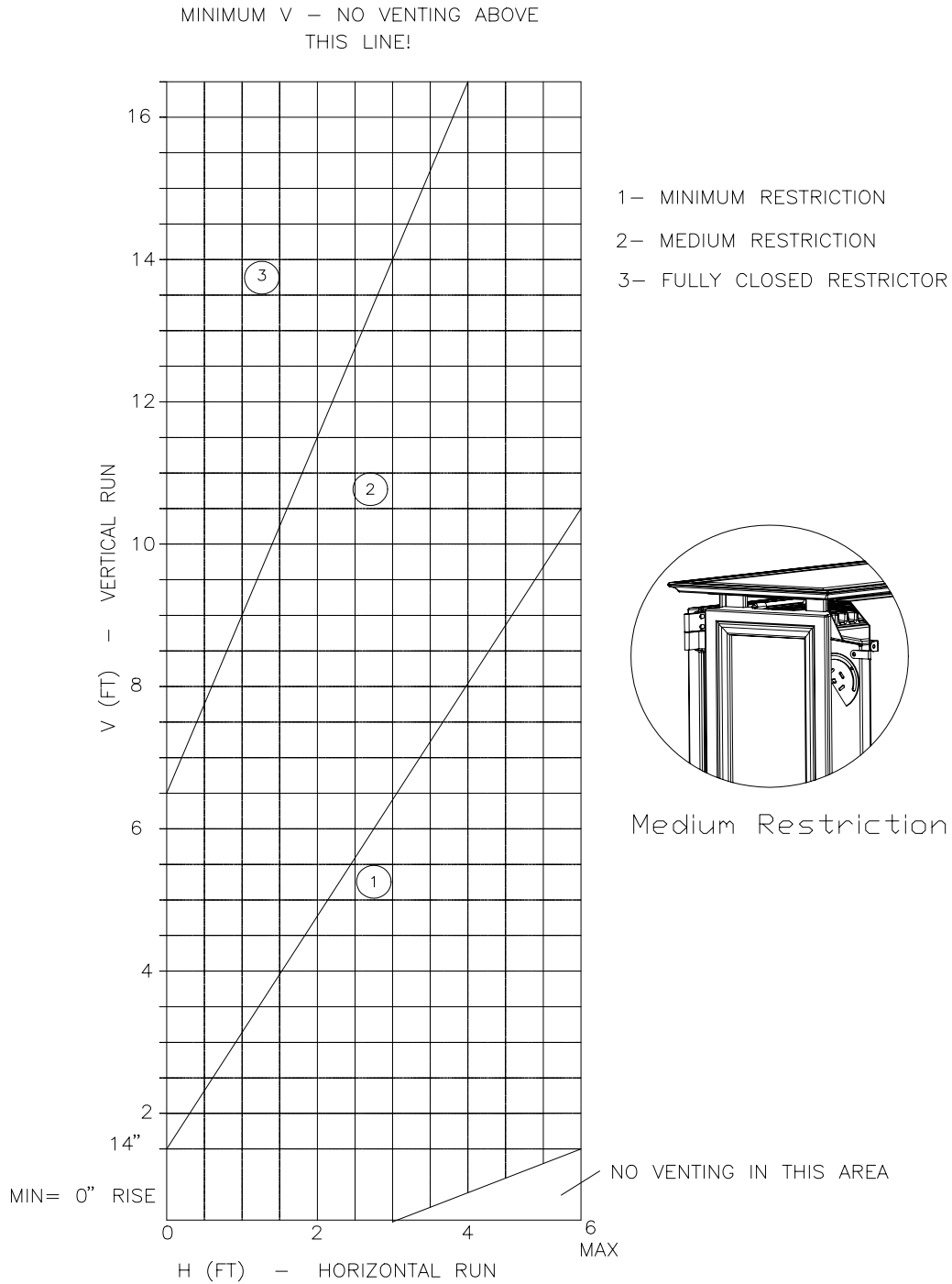

RESTRICTOR WIDE OPEN WITH UNDER 14" VERTICAL VENT  
 MINIMUM HORIZONTAL= 6"  
 MAXIMUM HORIZONTAL= 6' WITH 14" RISE  
 MAXIMUM HORIZONTAL WITH NO RISE = 3'  
 MAXIMUM HORIZONTAL RUN WITH 45 DEGREE ELBOW = 18"

**Figure 6 Venting configurations**



## VENTING COMPONENTS & CONFIGURATION

The Tudor cannot be vented jointly with any other solid fuel or gas appliance. It must be vented directly to the outside of the building using a proper termination as listed in the manual. The only types of venting pipe approved for use with your Tudor Direct-Vent stove is Simpson Dura-Vent's GS, AmeriVent Direct, Selkirk Direct Temp™ and Secure Vent Direct-Vent Pipe. The venting configuration is shown in *Figure 6*. After determining the venting configuration for your stove, select the vent system that will accommodate your installation.

**Caution: Be sure there is no wiring or plumbing in the chosen location.**

**Caution: Venting terminals shall not be recessed into a wall or siding.**

**Note:** If further direction is needed for installation, please refer to the venting instructions, which are provided with the venting components.

### Acceptable Direct-Vent Termination Cap Locations

The vent/air intake termination clearances above the high side of an angled roof are as follows:

Roof Pitch	Feet	Meters
Flat to 6/12	1	0.3
7/12 to 9/12	2	0.6
10/12 to 12/12	4	1.2
13/12 to 16/12	6	1.8
17/12 to 21/12	8	2.4

Listed are Simpson Dura-Vent, AmeriVent Direct, Selkirk Direct Temp™ and Secure Vent components acceptable for installation, along with the minimum venting kit

available. The venting system must be comprised of the appropriate venting components as specified.

## APPROVED VENTING SYSTEM COMPONENTS

**(THE FOLLOWING ARE COMPONENTS THAT ARE AVAILABLE, BUT NOT NECESSARY FOR ALL INSTALLATIONS)**

90° Elbow  
 45° Elbow  
 6" Straight  
 9" Straight (Simpson only)  
 12" Straight  
 24" Straight  
 36" Straight  
 48" Straight  
 11"-14 5/8" Adjustable Pipe Length  
 Horizontal Vent Cap  
 Vertical Vent Cap  
 14" Snorkel  
 Vinyl Siding Standoff 4 x 6 5/8"  
 Round Ceiling Support Wall  
 Thimble Covers  
 Wall thimble  
**Wall Pass Through Insulation Blanket (Required wherever a wall pass through is installed)**

## CHIMNEY LINER SYSTEM

1. Direct-Vent Chimney Liner Termination Kit
2. Chimney Liner Flex
3. Co-Linear Flex Connector
4. Co-Axial to Co-Linear Appliance Connect (**Masonry approved, not to exceed 16'**)

## MINIMUM VENT KIT

6" Straight  
 Wall Thimble Cover (optional)  
 Wall Thimble  
 Horizontal Vent Cap  
**Wall thimble Insulation Blanket (Supplied by HearthStone)**

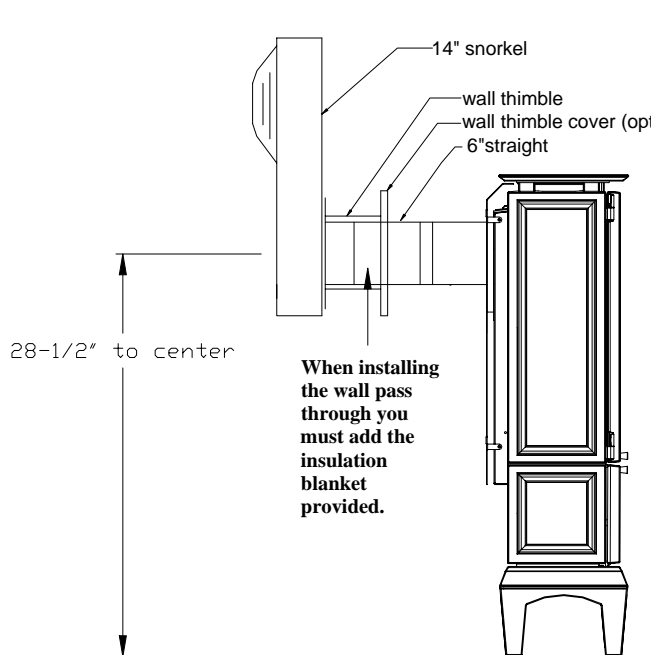

**Figure 7 Components for a typical snorkel installation**

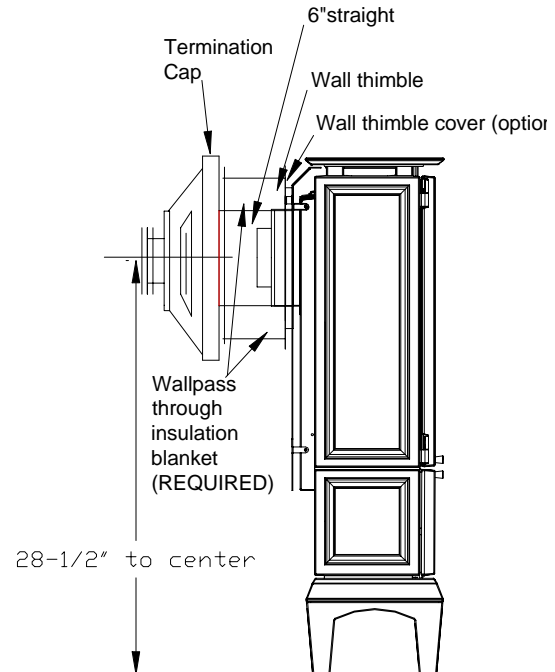

**Figure 8 Components for a minimum horizontal vent configuration**

## INSTALLATION INSTRUCTIONS FOR THE STANDARD HORIZONTAL TERMINATION MINIMUM VENTING KIT

1. Install the 6" straight over the outer collar.
2. Move the stove and pipe assembly back until the 6" straight is flush to the wall. Pull up on the pipe to ensure that there is a 1/4" per foot rise coming out of the stove.
3. Draw a circle around the pipe. Use the center of this circle as the center point of the 10" x 10" square wall pass through. Cut and frame the wall pass through.
4. Place the interior wall thimble into the 10" x 10" wall pass through. Secure it with 4 screws (not

provided). Install the exterior portion of the thimble in similar fashion, overlapping the 2 sections.

5. **Place the Wall Pass through Insulation Blanket inside of the wall pass through as described on page 11.**
  - **Caution:** For building with vinyl siding, a vinyl siding standoff should be installed between the vent cap and the exterior wall.
6. Install the horizontal vent termination on the outside of the wall. Make sure both of the retaining straps extend through interior wall thimble. Before attaching the vent termination to the outside of the house, run a bead of non-hardening mastic around its' outside edges, so as to make a seal between it and the wall. **The arrow on the end cap**

- should point up.** Secure the cap to the wall with the appropriate screws.
7. Move the stove and vent pipe into position. Make sure the 6" vent pipe extends into the horizontal vent cap a minimum of 1-1/4"). Also make sure the 6" pipe slides through the blanket insulation that is tucked inside the wall pass through thimble.
  8. Secure the vent using the straps from the horizontal vent termination to the interior 6" pipe with 2 sheet metal screws, keeping the screws close to the wall thimble as possible. Bend or cut the excess strapping, so that it is not visible after the installation is complete.

## ELECTRICAL CONNECTIONS

**NOTE:** OPEN VALVE DOOR IN THE LOWER FRONT FOR ELECTRICAL AND GAS CONNECTIONS.

### THERMOSTAT

The ON/OFF/T'stat switch or wall mounted thermostat controls the Tudor. We recommend installation of the thermostat for more comfortable performance, however you may still override the thermostat by setting the switch to "ON". The thermostat controls the unit by "calling for heat." The thermostat turns the unit on when the room is cold, and turns the unit off once the room is warmed sufficiently. The thermostat is controlled by a 750 millivolt DC two-wire circuit.

### REMOTE CONTROL

There are two different optional remote controls available for the Tudor. Both of the remote controls are capable of turning the unit on and off. One of the optional remotes also allows you to control the temperature of the stove, (in the same way the thermostat controls the heater), from anywhere in the vicinity of the unit. If "ON" & "OFF" are the only controls required, Kit #90-56912 can be used. If you would like to control the temperature via the remote control, use Kit #90-56914. Installation instructions are provided with the kits.

### THERMOSTAT PLACEMENT

The thermostat should be placed in the same room or living space as the unit. Typically 5' (1.5m) off the floor and away from any influences that may cause the temperature in the vicinity of the thermostat to be unrepresentative of the room temperature in general. Such influences might include strong lighting, a heater vent from the

central heating system, or a nearby drafty window.

Placement of the thermostat on an inside wall rather than an outside wall is preferable. Do not place the thermostat directly behind or too close to the unit, otherwise heat from the unit will immediately satisfy the thermostat and turn the unit off.

### THERMOSTAT WIRING

The thermostat should be connected to the Tudor using no more than 40' (12 m) of the provided insulated thermostat wire. The thermostat wire from the Tudor to the thermostat can be surface mounted or routed under the floor, through walls, etc.

Be sure to leave a small coil of additional thermostat wire behind the Tudor so that the unit can be moved out of position for servicing and cleaning.

Connect one of the thermostat wires to the gas control marked **TH** and the other to the yellow wire coming from the on/off T'stat switch. When making these connections, position the thermostat wire so that it extends towards the wall behind the Tudor, then towards the thermostat.

At the thermostat, the wires should be connected to the two connection screws on the back of the thermostat per the instructions received with the thermostat. Take care not to over-tighten the connection screws and not to damage the internal parts of the thermostat.

## WIRING INSTRUCTIONS

- CAUTION:** Label all wires prior to disconnection when servicing controls. Wiring errors can cause improper and dangerous operation. Verify proper operation after servicing. *(Attention: Au moment de l'entretien des commandes, étiquetez tous les fils avant le débranchement. Des erreurs de câblage peuvent entraîner un fonctionnement inadéquat et dangereux.)* The proper location of wire connections is shown in Figure 9.

### Wiring Diagram - Tudor

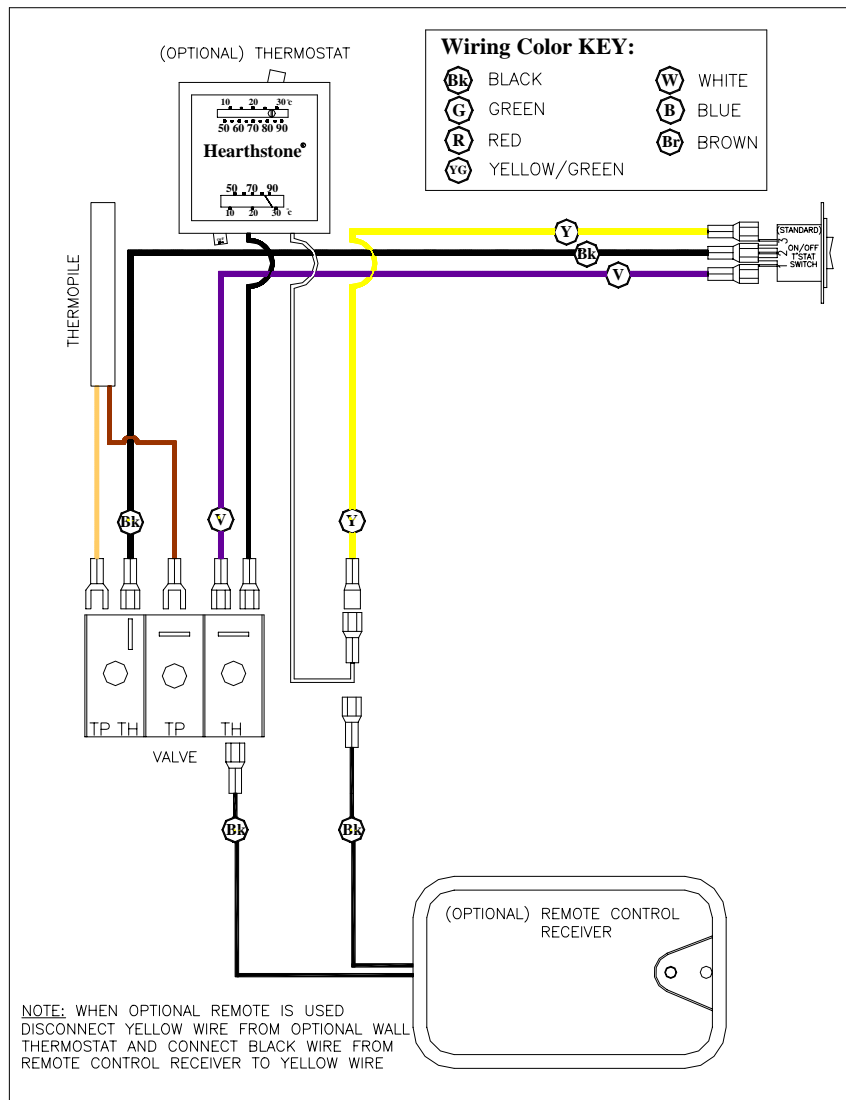

Figure 9 Wiring diagram

## VALVE DESCRIPTION

- |  |                              |                                   |
|--|------------------------------|-----------------------------------|
| ① Gas cock knob  | ⑥ Inlet pressure test point  | ⑪ Flange securing screw holes     |
| ② Manual HI-LO adjustment or pressure regulator adjustment | ⑦ Outlet pressure test point | ⑫ Additional valve mounting hole  |
| ③ Pilot adjustment   | ⑧ Main operator              | ⑬ Alternative TC connection point |
| ④ Thermocouple connection                                  | ⑨ Pilot outlet               | ⑭ Thermoelectric unit             |
| ⑤ Mounting for piezo & bracket                             | ⑩ Main gas outlet            |                                   |

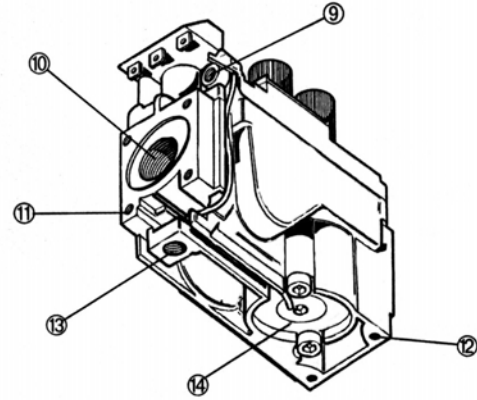
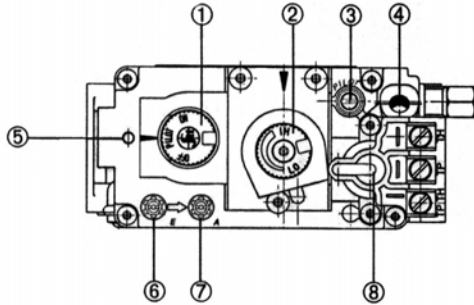

Figure 10 Gas control valve

## GAS SUPPLY & CONNECTIONS

- **NOTICE:** A qualified technician must connect the heater to the gas supply and leak test the unit before it is approved for use. Consult all codes.
- **WARNING:** The unit must be installed and connected in accordance with local codes, or in the absence of local codes, with the most current edition of the National Fuel Gas Code ANSI Z223.1 (NFPA 54) or CAN/CGA B149 Installation Code.
- NFPA Code, and Hearthstone require the use of a dedicated sediment trap just upstream of the unit. Damage to the valve, or other components due to the lack of a sediment trap are not covered by warranty.

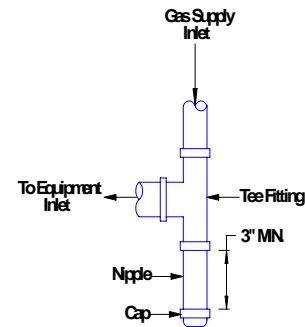

Figure 11 Typical Sediment Trap (Required in all installation)

## GAS CONNECTIONS

The gas supply connection is made to the Tudor's gas control valve in the middle of the lower rear of the stove, using a 3/8" male NPT fitting. The supply line should be 1/2" diameter, or appropriately sized to provide a sufficient gas supply to meet the maximum

demand of the unit without undue loss of pressure. We recommend a flexible line to avoid undue mechanical load on the valve and to ease thread alignment, but refer to local codes.

- **CAUTION: Check Gas Type!**

## **GAS SUPPLY**

This appliance and its individual shutoff valve must be disconnected from the gas supply piping system during any pressure testing of that system at test pressures in excess of ½ psig. The Tudor must be isolated from the gas supply piping system by closing its individual manual shutoff valve during any pressure testing of the gas supply piping system at test pressures equal to or greater than ½ psig.

## **GAS PRESSURE ADJUSTMENT**

**NOTE: A QUALIFIED TECHNICIAN MUST PERFORM THIS PROCEDURE!**

Once connected to the gas supply, the supply line and manifold gas pressures must be tested. The supply line pressure is tested, to insure it meets the minimum gas supply pressure as listed in the Specifications for the type of fuel in use (natural gas or LP), by connecting a manometer to the supply line and adjusting the incoming pressure if necessary to meet the required supply line pressure as listed in specifications. The manifold pressure tap on the gas control valve, refer to *Figure 10* for location.

## **FIRELOG PLACEMENT**

**CAUTION: Fragile!** Handle log set with care. Always wear gloves and safety goggles while handling the log set.

Only the Firelog set supplied with the Tudor should be placed in the firebox. Do not place any other logs, wood logs, or other materials in the firebox. If the log set is damaged or broken contact your dealer for replacement. It must be replaced with the same approved replacement parts. These components affect the combustion quality and safety of the heater. The Firelog set will last a long time, however, they will break if subjected to rough or improper handling. Exact positioning of the log set is required in order to obtain a pleasing flame pattern and efficient combustion. Incorrect log placement may cause carbon build-up; excess thermal stress on the log set and stove parts, reduced efficiency, and high levels of carbon monoxide. If the log set does not set into the firebox exactly as outlined, contact your dealer for assistance.

### **INSTALLATION OF THE FIRELOG SET**

- 1) Open the doors on the front of the unit, and remove the front cast and glass assembly. To remove the front, grasp both sides of the front cast facade, and lift upward and then outward. The whole piece is easily removed. Set the front aside taking care not to chip or scratch the enamel. Next, locate the two rotating clips above the glass. Rotate the clips out of the "locked" position and tilt the top of the glass outward. Lift the entire glass assembly up and out.
- 2) Gently take the Firelogs out of the firebox and remove the bubble wrap from the log set. Be careful not to damage the log set when unpacking. There are two logs, a Front and a Rear.

- 3) Gently place the TEK burner in the firebox. There are two locator tabs on the left side and one on the right side. Ensure these tabs find the mating slots in the firebox sides. When installed it should look like the figure below

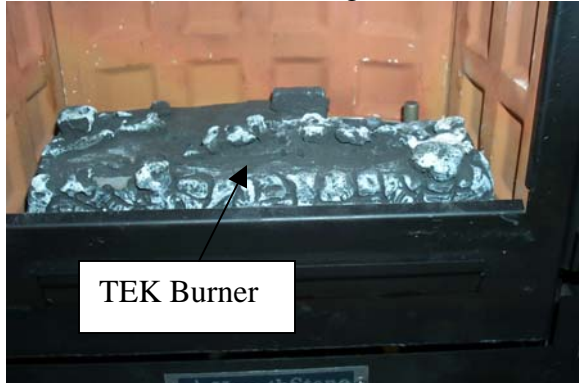

- 4) Place the Rear Log (1) in the firebox, on the ember burner. On the underside of the log there is a cutout that allows the pilot flame to reach the front burner under the log. Align the log in the appropriate position. It should sit as shown in the figure below.

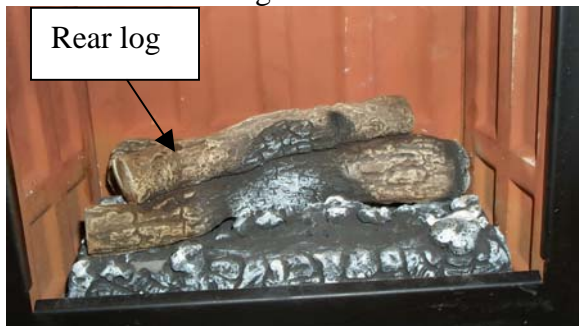

- 5) Gently place the Front Log (2) in the firebox, on the TEK Burner. On the top of the TEK Burner there is a cutout that allows the Front log to rest in place. It should sit as shown in the next figure.



- 6) Re-install the glass assembly by lining up the two tabs on the bottom of the assembly with the two slots on the firebox. Slide the lower portion of the glass assembly into the slots and push the top in against the firebox. Rotate the clips into the “locked” position. Re-install the front cast by sliding the upper portion onto the lip of the top and tilting the bottom in flush with the glass assembly. It should then be snug in place. Make sure the glass assembly is properly secured to the firebox before turning the unit on. Be careful not to chip the enamel when installing the glass assembly or front cast.

## REMOVAL OF LOG SET

**CAUTION:** The Firelog set retains heat and can be very hot! Allow 2 to 3 hours after pilot light is turned off before handling.

To remove the Firelog set, follow the Installation of Log Set instructions in the reverse order.

## LIGHTING THE UNIT FOR THE FIRST TIME

- **WARNING:** If you do not follow these instructions exactly, a fire or explosion may result causing property damage, personal injury or loss of life.
- **CAUTION:** Lighting the Tudor for the first time and adjustments to the unit should be performed by qualified service personnel.

This appliance is only for use with the type(s) of gas indicated on the rating plate. This appliance is not convertible for use with other gases, unless a certified kit is used.

*Cet appareil doit être utilisé uniquement avec les types de gas indiqués sur la plaque signalétique. Ne pas l'utiliser avec d'autres gas sauf si un kited conversion certifié est installé. )*

## SMOKE AND FUMES WARNING

When lit for the first time, the Tudor will emit some smoke and fumes. This is normal “off-gassing” of the paints and oils used in

the manufacturing and assembly of the unit. Open windows to vent the room if necessary. The off gassing and fumes will subside after the first 10 to 20 minutes of operation.

## ODORS AND IMPURITIES

A heater of this type may produce odors during heater operation due to impurities that may exist in the immediate area. Sources of impurities can be cleaning solvents, paint solvents, cigarettes, candles, smoke, pet hair, dust, adhesives, new carpet, and/or textiles. Such odors will dissipate. However, opening a window or otherwise providing additional ventilation to the area can alleviate the condition. If any odor persists, contact your dealer or an authorized service technician.

## PILOT LIGHT WARNING

The Tudor has a piezoelectric spark igniter (the red push button located next to the gas control valve behind the valve access door), which ignites the pilot light by means of a spark at the pilot light assembly. Do not attempt to light the unit with a match or by any means other than the piezoelectric spark.

## DO NOT LIGHT PILOT OR TEK BURNER BY HAND

The standing pilot light on this gas heater is lit by using a piezoelectric spark generator as described elsewhere in this manual. Never attempt to light the pilot or main burner by hand with a match or lighter. If, after repeated attempts, the pilot light fails to light, discontinue operation; turn off the gas at the gas control valve, and immediately contact qualified service personnel for assistance.

## PREPARE FOR LIGHTING

Prepare for the lighting procedure by adjusting the thermostat (if equipped) to its lowest setting or OFF position. If the gas control knob is not in the OFF position, turn the knob fully clockwise to OFF. Locate the variable output control knob and turn it fully clockwise to the highest setting.

Prior to lighting the unit for the first time, wait 5 minutes to allow any residual gas within the unit to dissipate. Smell all around the appliance area for gas. Be sure to smell next to the floor because some gases are heavier than air and will settle on the floor. If you do not smell gas after this five-minute period, proceed with the lighting procedure. If you do smell gas, **DO NOT** proceed with the lighting procedure. Instead, **immediately refer to the What To Do If You Smell Gas Warning, on the cover of this manual.**

**WARNING:** The valve control has an interlock device. After shutting off all gas flow, the pilot burner cannot be relit until the thermocouple has cooled, allowing the electromagnet to be released (approx. 60 seconds). The gas control knob is designed to operate by hand. Do not use any tools during this operation. Damaged knobs may result in serious injury.

## INITIAL ADJUSTMENTS

Once the Tudor has been set in place, connected and assembled as described in the “Clearances To Combustibles”, “Venting Components & Configurations,” “Electrical Connections”, and “Gas Supply and Connections” sections of this manual, the unit is almost ready to be lit for the first time. The manufacturer tests each unit prior to shipment, so ignition should take place without failure. However, a number of small adjustments may be necessary to compensate for variations in gas pressure, altitude, and other factors particular to each installation.

## VARIABLE OUTPUT CONTROL

The gas control valve is equipped with a variable output control. This control varies the rate of heat produced by the unit by varying the gas pressure to the TEK Burner. A combination of heat output and the thermostat setting affect the length of the burn cycle. If your stove turns on and off too often, try, first, reducing the burn cycle by turning the HI/LOW knob, on the control valve, to a lower setting. Using the variable output control, the heat output of the unit can be reduced for mild fall and spring months, or maximized for the colder winter months. This adjustment can be made, by the homeowner, as necessary by turning the variable output control knob to “HI”, “LO” or any setting in between.

## LIGHTING INSTRUCTIONS

**NOTE:** The gas control knobs and the piezo igniter are located behind the control valve access door, under the front of the unit.

1. STOP! Read the What To Do If You Smell Gas! Warning (on the cover of this manual).
  2. Set the on/off/T'stat switch or thermostat to the "OFF" position.
  3. Push in and turn gas control knob clockwise to "OFF". (*If not previously lit, the knob should be in this position.*)
  4. Wait (5) five minutes to clear out any gas. If you then smell gas, STOP! *Smell all around the appliance area for gas. Be sure to smell next to the floor because some gases are heavier than air and will settle on the floor. If you smell gas immediately follow the What To Do If You Smell Gas! warning on the cover of this Manual.* If you do not smell gas, proceed to the next step.
  5. Turn gas control knob counter-clockwise to "PILOT".
  6. Push in control knob all the way and hold in. Immediately light the pilot with the gas lighter (push in and "click" the piezoelectric spark igniter button several times until lit). Continue to hold the control knob in for about 20 seconds after the pilot is lit. Release the knob and it will pop back out. Pilot should remain lit. If the pilot goes out, repeat the operation.
- If knob does not pop out when released, stop, shut off the gas supply to the heater and immediately call a qualified service technician or gas supplier.
  - If the pilot will not stay lit after several tries, turn the gas control knob "OFF" and call a qualified service technician or gas supplier.

7. After the pilot lights, turn gas control knob counter-clockwise to "ON".
8. If the ON/OFF/T'stat switch is set to "ON", the stove should now be lit. If the thermostat (or remote) has been installed, set the ON/OFF/ T'stat switch to "T'stat" and turn the thermostat (or remote) to "ON". Then set the desired temperature.
9. Shut the gas control valve access door.
10. Plug in the fan accessory, if so equipped.
11. If T'stat was selected, set thermostat to "ON" and set desired temperature setting. Normally, if T'stat position was selected, the main burner is cycled on and off by the thermostat or the "on/off" switch located on the bottom of the thermostat body.

**NOTE:** When pressing/clicking the piezoelectric spark ignition button to light the pilot, watch through the glass (front) of the unit. Click the igniter button until a flame is visible at the pilot. Once the pilot is lit, continue to press on the gas control knob for another 20 seconds, then release. Ascertain that the pilot is still lit by looking through the front door. If lit, then turn the gas control knob fully counter-clockwise to the "ON" position. If the pilot fails to light, or if it went out due to a premature release of the gas control knob while depressed in the "PILOT" position, wait 60 seconds for the Interlock to release. Then repeat the lighting process as described in this section of the manual.

Once the pilot has been lit, the gas control knob has been turned to the "ON" position, and the ON/OFF/T'stat switch has been turned to "ON", the main burner should light immediately. If you would like to use the thermostat and it has been installed, switch the ON/OFF/T'stat switch to thermostat. Turn the thermostat to "ON" and set it to a higher position so that it "calls" for heat in order to light the main burner (i.e. turns the

unit on). Note that the thermostat controls the on/off cycling of the main burner, but the pilot remains lit regardless of the thermostat setting. The only way to turn the pilot off is to turn the gas control knob fully clockwise to the “OFF” position.

### TO TURN OFF GAS TO APPLIANCE

1. Set the thermostat to the “OFF” position or turn the ON/OFF/T-STAT switch to the “OFF” position.
2. If shutting the unit off for the non-heating season, turn the gas control knob fully clockwise to the “OFF” position. Do not force the knob to turn.

### AIR SHUTTER

The air shutter is used to regulate the air-to-gas combustion mixture, which in turn influences the size and color of the flames. The air shutter is positioned in the general location needed for the type of gas being used, however, if the unit is not burning as well as it should, then the air shutter may need adjusting. The air shutter may need adjustment once the unit has been installed to compensate for variations in supply line pressure, restriction plate position, altitude, gas type conversions, and other variables.

To determine if the air shutter needs adjustment, it is necessary to view the flame pattern with the variable output control knob at its highest setting. Allow the unit to operate for at least 10 minutes to allow the entire unit to reach temperature, and for the flame pattern to stabilize. Generally, the more air (open shutter) in the mixture, the bluer the flame. Less air (closed shutter) results in a more yellow flame, but too little air will result in incomplete combustion, low efficiency and a dirty burn. There are two simple guidelines to aid in determining the correct flame pattern:

1. If the flame at the base of the logs is completely blue, the air shutter may be open too far;
2. If the flame is dirty or licks the top of the stove, the air shutter may be closed too far.

Some conditions cannot be corrected through air shutter adjustment; an adjustment must be made to the gas supply pressure or by changing the restriction plate location. Qualified service personnel must perform supply line/manifold gas line pressure adjustments and restrictor plate adjustments. Do not attempt to complete any part of the installation or adjustment of this unit unless technically qualified to do so.

### AIR SHUTTER ADJUSTMENTS

The air shutter adjuster, located under the valve access door, in the lower front of the unit, is adjustable while the stove is burning. **Use a 5/16” wrench to loosen the air shutter locking nut while holding the screw prior to lighting the unit.** This nut will get very hot during operation and will be difficult to loosen. Turn the screw in to close the shutter or out to open it. Use only metal tools for this adjustment. When the burner starts to rise while turning the screw in the shutter is fully closed. Stop turning the screw in. When the flame pattern is correct, tighten the locking nut without turning the screw. The air shutter is factory set and only a qualified gas technician should make adjustments.

**Note:** Very little movement is needed to substantially change the burn and flame patterns. Some conditions cannot be corrected through air shutter adjustment; an adjustment must be made to the gas supply pressure. Supply line/manifold gas line pressure adjustments must be performed by qualified service personnel. Do not attempt

to complete any part of the installation or adjustment of this unit unless technically qualified to do so.

## PILOT ADJUSTMENT

The pilot light is preset by the manufacturer and should not need adjustment. The pilot light flame should be large enough to engulf the thermopile and thermocouple located next to the pilot, but not so large as to create excessive noise or consume excessive gas. (Refer to figure 10) However, it can be adjusted by means of the pilot light adjustment screw located on the gas control valve. Open the valve door to access the pilot adjustment screw. Note that the pilot flame must engulf the thermopile so that the thermopile can generate sufficient millivoltage (325 to 500-mv) to power the gas control valve. The flame on the pilot should look like Figure 120. Controlling the Tudor by the wall-mounted thermostat may become erratic, nonexistent, or the unit may go out, if the pilot flame is too small or misdirected away from the thermopile.

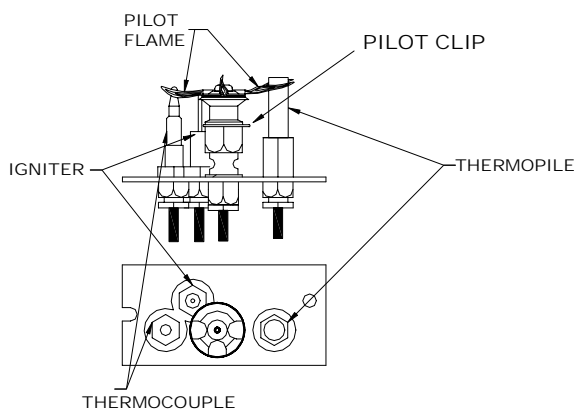

Figure 12 Pilot assembly

### • WARNING

The control has an interlock device. If the stove has been lit, it will not relight immediately. After shutting off all gas flow, the pilot burner cannot be relit until the thermocouple has cooled, allowing the

electromagnet to be released (*Approx. 60 sec.*). The gas control knob is designed to operate by hand. Do not use any tools during this operation.

## BURNER FLAME APPEARANCE

Once the unit is lit, observe the flame pattern and adjust as necessary. Also, a periodic visual check of the burner flame should be performed. The burner flames can be adjusted by means of the air shutter. To determine if the burner flame needs adjustment, it is necessary to view the flame pattern with the variable output control knob at its highest setting (turn fully clockwise). Allow the unit to operate for 10 minutes enabling the entire unit to reach temperature and for the flame pattern to stabilize. The flame pattern should be similar to the one shown in Figure 13. There are several guidelines to aid in determining if the flame pattern is correct:

1. The flame should not be dirty, smoky, sooty, or lick the top of the stove.
2. The flame should not rise off the TEK burner; this is called “lifting”.
3. Flames should not impinge heavily on the log set. They should “fit” through the pre-formed spaces designed in the log set.



Figure 13 Typical flame appearance

## ROUTINE MAINTENANCE AND CARE

The Tudor requires minimal routine maintenance and care. It should always be cool and off when being cleaned, or serviced. Once a year, the unit, and venting system should be inspected by qualified service personnel to insure that they are clean, free of obstruction, safe, and in good working order. If service or maintenance is required, qualified service personnel should perform it.

- **WARNING: Do not substitute materials.** For replacement parts, or for information about parts or service, contact your local HearthStone dealer.

### CLEANING

- **WARNING: Do not clean the unit when hot.**

The unit should receive regular cleaning on, under, and around the stove to prevent the buildup of dust and lint. The exterior surfaces of the unit can be cleaned using soap, water, and a soft cloth. **Do not** use abrasive or chemical cleaners and take care not to scratch the glass or enamel finish (if so equipped) when cleaning the unit. The use of chemical wax based cleaners or polishes are not recommended due to the potential for discoloration of the stones, castings or enamel when the residue of the cleaners or polishes are exposed to heat. Excessive buildup of dust, spider webs, or room air contamination may cause odors when the stove is hot.

### FIREBOX, PILOT, & BURNER ASSEMBLY

The firebox requires periodic cleaning to prevent the accumulation of dust, lint, and other debris. To clean the firebox, set the thermostat to the “OFF” position, and turn off the gas at the gas control valve. When

the unit is cool, open the front door, and remove the front cast and glass assembly. Carefully remove the decorative log set, taking care not to damage the logs or chip the enamel cast iron. Clean the firebox and TEK burner, and carefully vacuum the entire surface of the log set. Thoroughly vacuum the ports (holes) along the top of the TEK burner, and the pilot assembly.

With the decorative logs out of the firebox, re-install the glass assembly and front cast. Briefly light the unit according to the lighting instructions described on page 23. Check to insure a proper flame is burning from each burner port. The pilot flame should be large enough to engulf the thermopile and thermocouple as shown in Figure 25.

**NOTE: Do not operate the unit for more than 1-2 minutes without the log set in place. Turn the unit off by setting the thermostat to “OFF”, and turning the gas control valve off. Allow the unit to cool.**

Check and clean any burner ports that are not burning, or not burning properly. Clean burner ports using a soft brush or vacuum cleaner. If the pilot flame height needs adjustment, it should be adjusted by qualified service personnel as described on page 25.

Complete the cleaning procedure by carefully placing the log set within the firebox as described on page 20. Re-install the glass assembly and front cast. Turn on the gas, light the unit and check for proper operation. Flame patterns should look similar to the flames in Figure 13. Regularly check to insure the area around the Tudor is kept free from combustible materials, gasoline, and other flammable vapors and liquids. Check that the flow of

combustion and ventilation air is not obstructed.

## REPLACE THE GLASS GASKET AS NEEDED

Your Tudor uses a 3/4" tape-style fiberglass gasket to make a tight seal between the doorframe and the firebox. In time, the gasket can become brittle and compressed and should be replaced. New gasket material is available from your Authorized HearthStone Dealer. Protect your hands with work gloves, and wash up later.

1. Allow the Tudor to cool completely.
2. Remove the front cast and glass frame as described in the *Log Placement* section.
3. Using a 1/8" drill bit drill out the rivet in the top center of the glass frame. This will allow the glass to free up from the steel.
4. Remove the existing gasket by grasping one end and pulling firmly. Clean the remaining adhesive on the glass off with warm soapy water. Let dry.
5. Determine the correct length of the appropriate-sized gasket by wrapping it around in the glass. Allow an extra 1 to 2" (25-50mm), and mark the spot to be cut.
6. Cut the gasket at the marked spot with a utility knife.
7. Starting at one end, pull the paper off the back of the gasket and center the gasket over the glass. Continue around the glass

until you meet up where you started. Do not overlap the gasket ends or leave ends with ragged edges.

8. Firmly and evenly, press the gasket to seat it in its channel.
9. Sandwich the glass within the glass frame and glass gasket clip.
10. Using a 1/8"x1/8" rivet, reattach the glass gasket clip to the glass frame

## GLASS CLEANING

As fuel gas may contain some impurities; it will be necessary to clean the inside of the glass occasionally. Do not use abrasive cleaners. Scratching the glass will weaken the integrity of the glass. **Do not clean the glass when hot!** Allow the glass to cool and apply a mild window cleaning fluid. Special gas appliance window cleaner is available from your local HearthStone dealer.

- **WARNING:** Do not operate this appliance with the glass panel removed, cracked, or broken. Do not subject the door to abuse, such as striking or slamming shut. Replacement of the glass panel should be done by a licensed or qualified service person.

## VENTING

The venting system should receive a periodic examination by a qualified agency. If the vent-air system is disassembled for any reason, re-install per the instructions provided in the venting section of this manual, being sure to reassemble and reseal the venting properly.

# PARTS LISTS

Part #	Part Name
<b>CAST</b>	
2110-205	Tudor feet
2110-210	Tudor base
2110-220	Tudor front, lower control door
2110-250	Tudor side, left
2110-255	Tudor side, right
2110-260	Tudor door, left
2110-265	Tudor door, right
2110-268	Tudor façade
2110-275	Tudor base, heat exchanger
2110-277	Tudor heat exchanger
2110-280	Tudor top
<b>STEEL</b>	
5120-001	knob
5120-005	Door Hinge Left Assembly
5120-006	Door Hinge right Assembly
5120-010	Valve Bracket
5120-017	Shutter, Primary air plenum
5120-019	Primary air plenum
5120-020	Pilot Shield
5120-027	hinge angle control door
5120-028	front casting hinge
5120-030	front sheet metal Stone ret door
5120-032	Control panel
5120-038	knob extension, front door
5120-041	lower baffler support, LEFT
5120-042	lower baffler support, RIGHT
5120-050	firebox
5120-055	Glass retention frame
5120-057	heat shield , rear
5120-062	side stone clip right
5120-064	side stone clip left
5120-066	magnet support bracket
5120-070	air inlet chamber
5120-076	Restrictor
5120-078	Restrictor Indicator
5120-080	Glass retention clips
5120-082	Glass plate clip
5120-085	façade retention clip
5120-092	heat shield, top
<b>GAS COMPONENTS</b>	
7200-453	orifice NG #53
7210-008	fitting 3/8"NPTx3/8" comp 90deg
7210-103	IGNITOR:MILLIVOLT
7211-003	fitting 3/8"COMP x 1/4"NPT straight
7211-053	Gas manifold
7211-131	pilot orifice NG
7211-300	VALVE
7211-370	3 way pilot SIT
7211-407	SIT 1" knob extension ON/OFF
7211-404	SIT 1" knob extension HI/LO
7211-027	GAS LINE 3/8" X 6"
<b>CONVERSION KIT</b>	
7200-463	ORIFICE LP #63
7211-136	ORIFICE: PILOT,LP,.35mm,
7211-307	REGULATOR: VALVE,LP,SIT
<b>TEK BURNER (PYROTEK)</b>	
Refractory liner interior panel set	
3120-130	interior top
3120-131	interior left
3120-132	interior right
3120-133	interior rear
3120-125	heatshield: top

Part #	Part Name
7211-536	Ember bed
7211-537	rear log
7211-538	front log
<b>ELECTRICAL</b>	
7000-014	Thermostat wire 40'
7000-031	HARNESS: WIRE,ON/OFF
7000-200	3 way switch - ON/OFF/T-stat
<b>MISC</b>	
3030-044	Glass (17.7" x 10.8")
3300-334	Plate for 3 way switch - ON OFF Tstat
4700-0795	Magnet, round
3160-152	Gasket: Pilot
3160-155	Gasket: Exhaust starter collar
3160-157	Gasket: Inlet starter collar
3160-080	GASKET: TAPE,3/4" x 1/16"
3160-121	Heat exchanger base gasket
3160-123	Gasket: Burner
3160-122	Heat exchanger gasket
5701-0923TU	COLLAR: INLET/EXIT,4"x6-5/8",TUDOR
3120-126	Blanket Insulation 1" x 6.5" x 29"
<b>CURIO-All cast</b>	
2110-296	panel, cast; side or front, upper
2110-292	panel, cast: front, lower
2110-294	panel, cast: side, lower
3120-124	ceramic heatshield: front door
5120-053	CAST RETENTION, LEFT DOOR
5120-054	CAST RETENTION, RIGHT DOOR
4500-3436	10-24 x3/8 Screw (8)
<b>HEIRLOOM-Stone</b>	
Stone set (1141-233 Soapstone)(1153-233 Aut. Brown)	
1141-232	stone door/side Pol. soapstone
1141-231	stone front Pol. soapstone
1141-230	stone side sm Pol. soapstone
3160-120	Front door heat shield
5120-051	STONE RETENTION, FRONT DOOR
4500-3436	10-24 x3/8 Screw (8)
<b>KEEPSAKE-Grill+Cast</b>	
2110-296	panel, cast; side or front, upper
2110-292	panel, cast: front, lower
2110-294	panel, cast: side, lower
2110-298	grille, front door
5120-052	grille retention front door

**91-68200 Tile Insulation Kit** –This kit is required to lower surface temps and to retain the tiles you have purchased.

**WARNING:** *DO NOT SUBSTITUTE MATERIALS.* FOR REPLACEMENT PARTS, OR FOR INFORMATION ABOUT PARTS OR SERVICE, CONTACT YOUR AUTHORIZED HEARTHSTONE RETAILER. FOR THE NAME OF THE AUTHORIZED RETAILER NEAREST TO YOU, VISIT OUR WEBSITE [WWW.HEARTHSTONESTOVES.COM](http://WWW.HEARTHSTONESTOVES.COM), OR WRITE:

HearthStone Quality Home Heating Products  
317 Stafford Ave.  
Morrisville, Vermont 05661-8695  
E-Mail: [info@hearthstonestoves.com](mailto:info@hearthstonestoves.com)

## TROUBLESHOOTING

Symptom	Possible Cause	Corrective Action
1. Pilot will not light.	<p>A. Insufficient gas pressure, air in the pilot line, or dirty or kinked gas line.</p> <p>B. Pilot orifice plugged.</p> <p>C. Defective or misaligned electrode at pilot.</p> <p>D. Defective igniter.</p> <p>E. After sitting for "off" season (summer), pilot assembly may be dirty.</p>	<p>A. Using the piezo sparker, try to light the pilot. If it will not light, check the inlet gas pressure.</p> <p>B. Clean or replace the pilot assembly.</p> <p>C. If a match lights a pilot, check the electrode gap and location. Should be a 1/8" gap in the flame area.</p> <p>D. Check for a good connection between igniter and electrode. Check wire insulation. If properly connected and no spark, replace igniter.</p> <p>E. Clean or replace the pilot assembly.</p>
2. Pilot will not stay lit after carefully following lighting instructions.	<p>A. Low or too high gas pressure</p> <p>B. Faulty connections.</p> <p>C. Defective thermocouple.</p> <p>D. Pilot dirty or plugged.</p>	<p>A. Check for proper inlet pressure for the gas being used.</p> <p>B. Measure voltage between valve body and solder connection on the rear of the valve (where the blue wire connects). It should be no less than 7 mV.</p> <p>C1. Ensure that the thermocouple connection at the gas valve is tight.</p> <p>C2. Check thermocouple output using millivolt meter. Disconnect from valve and read voltage across wire ends. If the reading is less than 15 mV, replace the pilot assembly.</p> <p>C3. If burning NG, check pilot flame to see that it is impinging on the top of the thermocouple. Clean or replace pilot for maximum flame impingement.</p> <p>D. Clean or replace the pilot assembly.</p>

## TROUBLESHOOTING

Symptom	Possible Cause	Corrective Action
3. Pilot burning, no gas to main burner, valve knob in the "ON" position, thermostat and/or on/off/t'stat switch in the "ON" position.	<p>A. Thermostat switch or wires defective.</p> <p>B. Thermopile may not be generating sufficient voltage.</p> <p>C. Plugged burner orifice.</p>	<p>A. Check thermostat/wiring for proper connections. Place jumper wire across terminals at thermostat. If burner comes on, replace defective thermostat. If not OK, place jumper across thermostat wires at gas valve. If burner comes on, tighten connections, or replace faulty wires.</p> <p>B. Check thermopile output, using a milli-volt meter. Take the readings across generator terminals of the gas valve. (TPTH and TP). Milli-volt reading should be greater than 325 mV. If not, replace the pilot assembly. If the meter reading is OK, but the burner does not come on, replace the gas valve.</p> <p>C. Remove and check burner orifice, clean or replace. Note: do not use any metal cleaning device, as this may damage the orifice.</p>
4. Pilot and burner come on, but go out after some warm-up.	<p>A. Inconsistent, or insufficient flame on thermopile.</p> <p>B. Insufficient gas pressure.</p> <p>C. Excessive draft.</p>	<p>A. Adjust pilot flame size and assure that the flame is aimed directly at the thermopile.</p> <p>B. Check line pressure to ensure that the correct inlet pressure is present for the type of gas being used. If propane pressure is inconsistent, check for water condensation at the regulator.</p> <p>C. Check Restriction settings per this manual.</p>
5. Frequent pilot outage problem.	<p>A. Pilot flame may be too low or blowing, (high), causing the pilot safety to drop out.</p> <p>B. Excessive draft</p>	<p>A. Clean and/or adjust the pilot flame for maximum impingement on the thermopile and thermocouple.</p> <p>B. Check Restriction settings per this manual.</p>
6. Glass fogs	A. A normal result of gas combustion.	A. After the heater has warmed up, the glass should clear.
7. Blue Flames	A. A normal result during the first 20 minutes.	<p>A. Flames should begin to turn more yellowish after 20 minutes of burning.</p> <p>B. If the blue color stays; adjust the air shutter for a proper burn.</p>

## TROUBLESHOOTING

Symptom	Possible Cause	Corrective Action
8. Floating flames, lazy ill-defined, quiet flames, which roll around, sometimes completely off of the port, sometimes with overly, yellow tips. Possible sooting. Usually accompanied by the odor of aldehydes.	<p>A. Potentially dangerous incomplete combustion due to incorrect air to fuel ratio (lack of combustion air or excessive fuel delivery i.e. excessive gas pressure, overrating of appliance).</p> <p>B. Incorrect air intake/exhaust flow system. Causes may be:</p> <p>B1. Blocked burner. B2. Blocked primary air B3. Blocked secondary air inlets</p>	<p>A. Check the appliance input rate and reduce if necessary. The air intake/exhaust flow system may be too restrictive or blocked (the rate at which the exhaust leaves [draft] determines the rate at which the combustion air is delivered). Poor draft results in insufficient air delivery or a restricted exhaust. Correct air intake/exhaust flow system.</p> <p>B1. Clear ports. B2. Clear obstructions. B3. Clear obstructions.</p> <p>C. If gas pressures are correct and the flames stay the same, adjust the air shutter for a proper burn.</p>
9. Burner flashback. Air-gas mixture ignites inside the burner near the orifice, usually creating a roaring noise like a blowtorch. The problem is an imbalance of gas flow velocity and burning speed pattern.	<p>A. Excessive primary air.</p> <p>B. Burner input underrated.</p> <p>C. Valve leak if flashback occurs with burner valve in off position.</p> <p>D. Improper gas pipe size.</p>	<p>A. Adjust the air shutter for a proper burn.</p> <p>B. Check input rate. Check input pressure using a manometer. Confirm correct gas pressure at house meter or tank (call gas company). Confirm burner orifice size.</p> <p>C. Replace valve. If above corrections do not eliminate flashback, replace burner.</p> <p>D. Correct plumbing.</p>
10. Delayed ignition (makes a sudden "whoosh" noise as the burner lights). This is a buildup of gas prior to ignition. This is more prevalent with propane (LP) fuel.	<p>A. Incorrect air-to-fuel ratio.</p> <p>A1. Primary air incorrect. A2. Burner ports plugged.</p> <p>B. Improper log placement.</p>	<p>A1. Adjust the air shutter for a proper burn.</p> <p>A2. Open ports to allow for proper travel of flames.</p> <p>B. Reposition logs to eliminate interference with flame travel.</p>

# RATING LABEL

MODEL # 8120-  
 SERIAL #



MODEL NAME: TUDOR DIRECT VENT GAS FIRED HEATER  
 LISTED: GAS FIRED DIRECT VENT HEATER  
 TESTED TO: ANSI Z21.88-2002 CSA 2.33-M02, CAN/CGA-2.17-M91

CERTIFIED FOR CANADA/HOMOLOGUE POUR LE CANADA  
 ALSO FOR MOBILE HOME INSTALLATION

**CAUTION: DO NOT OPERATE WITH GLASS REMOVED, CRACKED, OR BROKEN.**  
 Replacement on the panel should be done by a licensed or qualified service person.  
**CAUTIONNER:** N'opère l'appareil avec le verre enlevé, craqué ou cassé. Le remplacement du panneau devrait être fait par une personne de service qualifié ou autorisé.

This appliance must be installed in accordance with the local codes, if any, if not; follow the National Fuel Gas Code, ANSI Z223.1 or Canadian Installation Codes, CAN/CGA B149. (Installer l'appareil selon les codes ou règlements locaux, ou, en l'absence de tels règlements, selon les Codes d'installation CAN/CGA-B149.)

FUEL TYPE:	■ NG	■ LP
INPUT RATING (Btu/hr) 0-2000 ft	11,500	11,200
ORIFICE SIZE (DMS) 0-2000 ft	53	63
MANIFOLD PRESSURE - LO (in. W.c./kpa)	1.6/0.42	6.4/1.59
MANIFOLD PRESSURE - HI (in. W.c./kpa)	3.5/1.15	10.0/2.48
MINIMUM INLET PRESSURE (in.w.c./kpa)	5.0/1.24	11.0/2.88
MINIMUM INPUT RATING (btu/hr) 0/2000 ft	7,000	8,500
MAXIMUM OUTPUT (btu/hr) 0-2000 ft	7652	7494

**WARNING:** Improper installation, adjustment, alteration, service or maintenance can cause injury or property damage. Refer to the owner's information manual provided with this appliance. For assistance or additional information consult a qualified installer, service agency or the gas supplier. (L'AVERTISSEMENT: L'installation inconvenante, ajustement, modification, service ou entretien peut causer le dommages de propriété ou blessure. Référez au manuel d'information de propriétaire fourni cet appareil. Pour l'assistance ou information supplémentaire consultez un qualifiée installateur, agence de service ou le fournisseur de gaz.)

### MINIMUM CLEARANCES TO COMBUSTIBLES

UNIT TO REAR WALL	0" / 0 mm
UNIT TO SIDE WALLS	8" / 204 mm
CORNER	1" / 26 mm

There are two different remote controls (kit #90-56912 & kit #90-56914) available through HearthStone or your local HearthStone dealer.

This appliance is only for use with the type of gas indicated on this rating plate and may be installed in an aftermarket, permanently located, manufactured (mobile) home where not prohibited by local codes. See owner's manual for details. This appliance is not convertible for use with other gases, unless a certified kit is used. If the vent air intake system is disassembled for any reason, reinstall per the instructions provided with the initial instructions. This vented gas fireplace heater is not for use with air filters. This appliance must be properly connected to a venting system in accordance with the manufacturer's installation instructions.

VENTED GAS FIREPLACE HEATER - NOT FOR USE WITH SOLID FUEL.



MANUFACTURED BY: HearthStone, MORRISVILLE, VERMONT 05661

### Date of Manufacture

2004 2005 2006 Jan Feb Mar Apr May Jun Jul Aug Sep Oct Nov Dec

DO NOT REMOVE OR COVER THIS LABEL

MADE IN USA

3300-579

## HEARTHSTONE GAS-FIRED STOVE AND INSERT LIMITED WARRANTIES

**These warranties give you specific legal rights. You may also have other rights that vary from State to State.**

HearthStone Quality Home Heating Products, Inc. (HearthStone) warrants **to the original purchaser only** (the “Original Purchaser”) the new gas-fired stove/insert manufactured by HearthStone and purchased by the Original Purchaser (referred to as the “Stove” for simplicity) against any of the occurrences listed in this document that result from defects in material or workmanship. All obligations of HearthStone under this document commence on the date the Original Purchaser purchases the Stove (the “Purchase Date”).

### **LIMITED LIFETIME WARRANTY**

HearthStone warrants the following parts of the Stove against the following occurrences that result from defects in material and workmanship:

- All cast iron parts, including the cast iron heat exchanger – against breakage, cracking or burn-through.
- All stones – against cracking or breakage due to thermal stress, **excluding** surface and hairline cracks and scratches that do not affect the operation or safety of the Stove.
- Glass – against breakage due to thermal shock.

### **LIMITED FIVE-YEAR WARRANTY**

HearthStone warrants the following parts of the Stove against the following occurrences that result from defects in material and workmanship:

- Firebox and firebox baffle – against breakage, cracking or burn-through.
- Convective heat exchanger – against breakage, cracking or burn-through.
- Burners, air shutters and orifices – against breakage, cracking or burn-through.
- TEK logs and embers – against breakage, cracking or burn-through.

**This warranty expires on the fifth (5<sup>th</sup>) anniversary of the Purchase Date.**

### **LIMITED THREE-YEAR WARRANTY**

HearthStone warrants the following parts of the Stove against the following occurrences that result from defects in material and workmanship:

- Gas train, including gas valve, millivolt wiring, spill switch, pilot assembly, thermopile, thermocouple, piezo igniter, and, if the Stove is a vent-free model, ODS system – against breakage or malfunction.

**This warranty expires on the third (3<sup>rd</sup>) anniversary of the Purchase Date.**

### **LIMITED ONE-YEAR WARRANTY**

HearthStone warrants the following parts of the Stove against the following occurrences that result from defects in material and workmanship:

- Enamel Finish – against peeling or fading, **excluding** chipping, mechanical abrasion, chemical abrasion or crazing.
- Gaskets and sealants – against breakage or deterioration.
- Accessories and electrical components such as blowers, switches and thermo discs, **excluding** venting components, hearth components, electrical components and other components or accessories used in conjunction with the installation of the Stove *not* manufactured, or supplied by HearthStone – against breakage or malfunction.

**This warranty expires on the first (1<sup>st</sup>) anniversary of the Purchase Date.**

### **EXCLUSIONS**

The warranties contained in this document do not cover, nor is HearthStone responsible for:

1. Damage resulting from installation or operation of the Stove in a manner contrary to the owner’s manual.

2. Damage or non-performance resulting from faulty or incomplete setup, installation and start-up or mishandling, abuse, or misuse of the Stove, including but not limited to over-firing.
3. Damage resulting from installation, modification, alteration, repair or service of the Stove by any party other than HearthStone or an authorized HearthStone dealer (a "Dealer").
4. Damage due to water or due to installation of the Stove in a damp or high condensation area.
5. Damage due to installation of the Stove in an atmosphere contaminated by damaging chemicals, including but not limited to chlorine, fluorine or salts.
6. Scratches on glass, enameled surfaces or stones due to mechanical abrasion.
7. Standard wear and tear of the Stove resulting from normal usage over time.
8. Damage, operational-related problems, or inadequate performance caused by site, installation or environmental conditions beyond HearthStone's control, including but not limited to nearby trees, rooftops, buildings, wind, hills, mountains, inadequate or excessive venting, insufficient make up air, or negative air pressure whether or not caused by mechanical systems such as furnaces, exhaust fans, clothes dryers, etc.
9. A defect in any part of the Stove if the Original Purchaser fails to comply with HearthStone's or a Dealer's request to ship the part or the Stove to HearthStone or a Dealer, as the case may be.

THE WARRANTIES CONTAINED IN THIS DOCUMENT ARE EXCLUSIVE AND ARE GIVEN BY HEARTHSTONE AND ACCEPTED BY THE ORIGINAL PURCHASER IN LIEU OF ALL OTHER EXPRESS WARRANTIES AND ANY OBLIGATIONS, LIABILITIES, RIGHTS, CLAIMS, OR REMEDIES IN CONTRACT OR TORT, WHETHER OR NOT ARISING FROM HEARTHSTONE'S NEGLIGENCE, ACTUAL OR IMPUTED. ALL IMPLIED WARRANTIES, INCLUDING THE WARRANTIES OF MERCHANTABILITY AND FITNESS FOR A PARTICULAR PURPOSE, ARE GIVEN **ONLY** TO THE EXTENT REQUIRED BY FEDERAL OR STATE LAW. EXCEPT AS OTHERWISE REQUIRED BY STATE LAW, UPON THE EXPIRATION OF THE EXPRESS LIMITED WARRANTIES CONTAINED HEREIN, **NO** IMPLIED WARRANTIES, INCLUDING THE IMPLIED WARRANTIES OF MERCHANTABILITY OR FITNESS FOR A PARTICULAR PURPOSE, SHALL APPLY TO THE SUBJECT STOVE. **SOME STATES DO NOT ALLOW LIMITATIONS ON HOW LONG AN IMPLIED WARRANTY LASTS, SO THE ABOVE LIMITATION MAY NOT APPLY TO YOU.**

THE WARRANTIES CONTAINED IN THIS DOCUMENT EXTEND **ONLY** TO THE ORIGINAL PURCHASER OF THE STOVE WARRANTED HEREUNDER. THEY DO NOT EXTEND TO ANY SUBSEQUENT OWNERS.

UNDER NO CIRCUMSTANCES SHALL HEARTHSTONE BE LIABLE TO THE ORIGINAL PURCHASER OR ANY OTHER PERSON FOR ANY INCIDENTAL OR CONSEQUENTIAL DAMAGES, INCLUDING BUT NOT LIMITED TO DAMAGE TO PROPERTY OR PERSONAL INJURIES, WHETHER ARISING OUT OF BREACH OF WARRANTY, TORT, OR OTHERWISE, EVEN IF HEARTHSTONE HAS BEEN APPRAISED OF THE POSSIBILITY OF SUCH DAMAGES. **SOME STATES DO NOT ALLOW THE EXCLUSION OR LIMITATION OF INCIDENTAL OR CONSEQUENTIAL DAMAGES, SO THE ABOVE LIMITATION OR EXCLUSION MAY NOT APPLY TO YOU.**

## **QUALIFYING FOR WARRANTY COVERAGE**

To obtain performance of any obligation under this document, the Original Purchaser must, **within the applicable warranty time period**, contact their dealer, or HearthStone, at the address listed in the Warranty Registration section below for instructions regarding the return of defective parts for repair, the return of the Woodstove for repair, or a Dealer service call. The Original Purchaser should refer to the Dealer network search engine contained on HearthStone's Web site ([www.hearthstonestoves.com](http://www.hearthstonestoves.com)) to find a HearthStone Dealer nearest the Original Purchaser's current location.

**REMEDY** The remedy for any breach of the foregoing warranties will consist of repair or replacement, at HearthStone's option, of any covered defect in the Stove. When the Original Purchaser contacts a Dealer, or HearthStone - the Dealer, or HearthStone as the case may be, will instruct the Original Purchaser to **either** return the defective part, or the entire Stove (if needed), with shipping prepaid, to the Dealer, or HearthStone, **or** allow a Dealer to make a service call at the place where the Stove is located. In the event the Original Purchaser refuses to allow a Dealer to make a service call, HearthStone or a Dealer, as the case may be, will request that the Original Owner return the defective part, or the entire Stove (if needed), with shipping prepaid, to HearthStone or a Dealer. **Notwithstanding any other provision of this document, the Original Purchaser shall pay for any travel fees and service charges related to a Dealer's service call.**

**Parts:** HearthStone will replace defective parts covered by the foregoing warranties at no charge.

**Labor:** Within the first (1<sup>st</sup>) year after the Purchase Date, HearthStone will pay for warranty labor performed by a Dealer at HearthStone's published labor rates in effect at the time the labor is performed. Thereafter, the Original Purchaser is responsible for the cost of labor.

**Shipping cost for parts:** Within the first ninety (90) days after the Purchase Date, HearthStone will pay for the shipping of Stove parts covered by any of the foregoing warranties to and from HearthStone or a Dealer, as the case may be. Thereafter, the Original Purchaser is responsible for all shipping costs related to shipping Stove parts to and from HearthStone or a Dealer, as the case may be.

**Shipping cost for the Stove:** Within the first (1<sup>st</sup>) year after the Purchase Date, if the Original Purchaser is instructed to return the Stove to HearthStone or a Dealer for repair, HearthStone will pay fifty percent (50%) and the Original Purchaser will pay fifty percent (50%) of the shipping costs related to shipping the Stove to and from HearthStone or a Dealer, as the case may be. Thereafter, the Original Purchaser is responsible for one hundred percent (100%) of all of the shipping costs related to shipping the Stove to and from HearthStone or a Dealer, as the case may be. Notwithstanding any other provision of this document, in no event will HearthStone pay for any Dealer fees or other fees for pick up or delivery of the Stove returned for repair; the Original Purchaser shall be responsible for any such fees.

## **WARRANTY REGISTRATION**

The Original Purchaser may send a completed and signed Warranty Registration Form, which is enclosed in the Stove warranty packet, to the following address:

HearthStone Quality Home Heating Products, Inc.  
Warranty Department  
317 Stafford Avenue  
Morrisville, VT 05661-8695

**NOTE: SENDING IN THE SIGNED WARRANTY REGISTRATION FORM IS *NOT* A CONDITION OF WARRANTY COVERAGE OR HEARTHSTONE'S PERFORMANCE.**